

# Assembly Instructions

## Gripping System FQE

**Note**

The Assembly instructions were originally written in German. Store in a safe place for future reference. Subject to technical changes without notice. No responsibility is taken for printing or other types of errors.

**Published by**

© J. Schmalz GmbH, 08/22

This document is protected by copyright. J. Schmalz GmbH retains the rights established thereby. Reproduction of the contents, in full or in part, is only permitted within the limits of the legal provisions of copyright law. Any modifications to or abridgments of the document are prohibited without explicit written agreement from J. Schmalz GmbH.

**Contact**

J. Schmalz GmbH  
Johannes-Schmalz-Str. 1  
72293 Glatten, Germany  
T: +49 7443 2403-0  
schmalz@schmalz.de  
www.schmalz.com

Contact information for Schmalz companies and trade partners worldwide can be found at:  
[www.schmalz.com/salesnetwork](http://www.schmalz.com/salesnetwork)

# Contents

<b>1</b>	<b>Important Information</b>	<b>5</b>
1.1	Warranty and Liability	5
1.2	The technical documentation is part of the product	5
1.3	Note on Using this Document	5
1.4	Warnings in This Document	6
1.5	Symbol	6
1.6	Type Plate	6
1.7	Other Applicable Documents	6
<b>2</b>	<b>Fundamental Safety Instructions</b>	<b>7</b>
2.1	Intended Use	7
2.2	Non-Intended Use	7
2.3	Danger Zone	7
2.4	Environmental and Operating Conditions	8
2.5	Personnel Qualifications	9
2.6	Personal Protective Equipment	9
2.7	Technical Condition	10
2.8	Responsibility of the Integrator	10
2.9	Country-Specific Regulations for the Operating Company	10
<b>3</b>	<b>Product Description</b>	<b>11</b>
3.1	Description of the Gripper	11
3.2	FQE ... M	12
3.3	FQE ... Xb	13
3.4	FQE ... Xc	14
<b>4</b>	<b>Technical Data</b>	<b>15</b>
4.1	General Parameters	15
4.2	Dimensions	17
4.3	Pneumatic Circuit Diagram (Version FQE ... Xc)	18
4.4	Circuit Diagram for Valves (Version FQE ... Xc)	19
4.5	Display Elements (Version FQE ... Xc)	20
<b>5</b>	<b>Transport and Storage</b>	<b>21</b>
5.1	Checking the Delivery	21
5.2	Reusing the Packaging	21
<b>6</b>	<b>Installation</b>	<b>22</b>
6.1	Installation Instructions	22
6.2	Mechanical Attachment	22
6.3	Electrical Connection	25
6.4	Pneumatic connection	27
<b>7</b>	<b>Start of Operations</b>	<b>29</b>
7.1	Personnel Qualification	29
7.2	Before Initial Start of Operations	29
<b>8</b>	<b>Operation</b>	<b>32</b>
8.1	Preparations	32

<b>9</b>	<b>Troubleshooting</b> .....	<b>33</b>
9.1	Safety .....	33
9.2	Faults, Causes, Solutions .....	34
<b>10</b>	<b>Maintenance</b> .....	<b>35</b>
10.1	Safety .....	35
10.2	Maintenance Schedule .....	36
10.3	Cleaning the Gripper.....	36
10.4	Removing the Ejector Module .....	37
10.5	Disassembling and Cleaning the Silencer Inserts.....	38
10.6	Removing the Sealing/Suction Plate .....	39
10.7	Replacing the Sealing Plate (Foam).....	39
10.8	Replacing Screw-in Suction Cups.....	40
10.9	Replacing Plug-in Suction Cups .....	41
10.10	Accessories, Spare Parts and Wearing Parts.....	42
<b>11</b>	<b>Disposing of the Product</b> .....	<b>46</b>
<b>12</b>	<b>Declarations of Conformity</b> .....	<b>47</b>
12.1	EU Declaration of Incorporation .....	47
12.2	UKCA Declaration of Incorporation .....	48

# 1 Important Information

## 1.1 Warranty and Liability

J. Schmalz GmbH, as a supplier and manufacturer of vacuum technology, takes no responsibility for the function of the product described below in a specific process.

The exact application parameters and the individual environment are decisive factors for selecting the right components.

The specifications for our products are based on our current technical knowledge and experience, as well as the available literature. We encourage you to test the products under the specific conditions that apply to your application purposes, and we would be glad to use our experience to assist you.

The packaging material, the goods that are packaged, the fill level, porosity, surface condition, center of gravity or the air content of the workpiece influence the entire handling process.

Following functional testing, different suction cup sizes, additional suction cups, a higher suction rate or modifications to the configuration may be necessary.

Therefore, J. Schmalz GmbH accepts no liability and excludes all legal claims for damages.

The products and the configurator are subject to technical changes or further development without notice.

We are not liable for any damage resulting from the use of non-original spare parts or accessories.

The exclusive use of original spare parts is a prerequisite for the proper functioning of the gripper and for the validity of the warranty.

Wearing parts are not covered by the warranty.

## 1.2 The technical documentation is part of the product

1. For problem-free and safe operation, follow the instructions in the documents.
2. Keep the technical documentation in close proximity to the product. The documentation must be accessible to personnel at all times.
3. Pass on the technical documentation to subsequent users.
  - ⇒ Failure to follow the instructions in these Assembly instructions may result in life-threatening injuries!
  - ⇒ Schmalz is not liable for damage or malfunctions that result from failure to heed these instructions.

If you still have questions after reading the technical documentation, contact Schmalz Service at:

[www.schmalz.com/services](http://www.schmalz.com/services)

## 1.3 Note on Using this Document

J. Schmalz GmbH is generally referred to as Schmalz in these Assembly instructions.

These Assembly instructions contain important notes and information about the different operating phases of the product:

- Transport, storage, start of operations and decommissioning
- Safe operation, required maintenance, rectification of any faults

The Assembly instructions describe the product at the time of delivery by Schmalz.

## 1.4 Warnings in This Document

Warnings warn against hazards that may occur when handling the product. The signal word indicates the level of danger.

Signal word	Meaning
DANGER	Indicates a high-risk hazard that will result in death or serious injury if not avoided.
WARNING	Indicates a medium-risk hazard that could result in death or serious injury if not avoided.
CAUTION	Indicates a low-risk hazard that could result in minor or moderate injury if not avoided.
NOTE	Indicates a danger that leads to property damage.

## 1.5 Symbol



This symbol indicates useful and important information.

- ✓ This symbol represents a prerequisite that must be met prior to an operational step.
- ▶ This symbol represents an action to be performed.
- ⇒ This symbol represents the result of an action.

Actions that consist of more than one step are numbered:

1. First action to be performed.
2. Second action to be performed.

## 1.6 Type Plate

The type plate is permanently attached to the product and must always be clearly legible.

The type plate contains the following data:

- Product key
  - Product service number
  - Order number
  - QR code – access to the Schmalz app
- ▶ Please specify all the information above when ordering replacement parts, making warranty claims or for any other inquiries.

## 1.7 Other Applicable Documents

Depending on the configuration of the gripper FQE, the following operating instructions must also be observed:

- The operating instructions for the ejector nozzle SEP
- The operating instructions for the vacuum switch VSi

## 2 Fundamental Safety Instructions

### 2.1 Intended Use

The product described below is a universal gripper and is therefore not limited to a specific application. Due to its small size, low weight and energy efficiency, the gripper is suitable for applications on small robots or even for human-robot collaboration applications.

The system must be operated only at the supply voltage specified for the components.

The load must only be vacuum-gripped in the position defined in advance or on initial set-up of the product.

Ensure that the load cannot slide or tip over during all phases of operation.

Use only the connections, mounting holes and attachment materials that have been provided.

The gripping system is built in accordance with the latest standards of technology and is delivered in a safe operating condition; however, hazards may arise during use.

The maximum lift capacity must not be exceeded (> See ch. Technical Data).

### 2.2 Non-Intended Use

Schmalz accepts no liability for damage caused by the use of the gripper for purposes other than those described under Intended Use.

Non-intended use includes the following:

- Lifting people or animals
- Storing loads while picked up
- Supporting the lifting process by applying external forces
- Applying suction to building components, equipment or supporting surfaces.
- Applying suction to bulk materials (e.g. granulates)
- Evacuation of objects that are in danger of imploding
- Use in potentially explosive atmospheres
- Removing building components or fixtures.

### 2.3 Danger Zone

Persons in the danger zone of the gripper FQE may suffer life-threatening injuries.

Gripper operating modes

- Automatic operation on the industrial robot or gantry
- Collaborative operation on the lightweight robot (cobot)

For both operating modes, the system integrator must carry out a risk assessment of the entire system and define the danger zone precisely. In doing so, country-specific provisions and regulations must be observed.

Automatic operation on the industrial robot or gantry

- During automatic operation of the handling system, no persons or animals may be present in the danger zone.
- In other operating modes, ensure that no unauthorized persons or animals are present in the danger zone.
- Ensure that collisions with the surrounding environment and objects are avoided to prevent the load from breaking off.

During automatic operation of the handling system, the danger zone must be secured to prevent access by persons (protective barrier or sensor system).

The danger zone of the gripper FQE includes the following areas:

- The area directly below the gripper and load.
- The area immediately surrounding the gripper and load.
- The working area of the automatic handling system.

## 2.4 Environmental and Operating Conditions

The gripping system must **not** be operated under the following conditions:

- In potentially explosive atmospheres
- Use in an environment with acidic or alkaline media



### CAUTION

**Dangerous gases, vapors or dusts are sucked in and dispersed by the vacuum generator.**

Difficulty breathing.

- ▶ Before commencing work, ensure that the ambient air does not contain any hazardous substances.
- ▶ Make sure that there are no hazardous substances on the load that can be sucked in.
- ▶ If the ambient air is dusty, use a dust filter (particle size max. 5 µm).



### CAUTION

**Blockage of the vacuum system from sucking in liquids**

Risk of injury from falling load!

- ▶ Do not pick up liquids or bulk materials.
- ▶ Observe the vacuum display.
- ▶ If the suction of liquids cannot be avoided, use a water separator (contact Schmalz service).

The gripping system must be operated only under the following conditions:

- The environment must be free from humidity, moisture, dirt, dust, oil or other climatic conditions that may reduce friction levels.
  - The gripping system must be sufficiently dimensioned for the loads to be lifted.
- ▶ If in doubt, consult Schmalz before the start of operations.



## 2.5 Personnel Qualifications

Unqualified personnel cannot recognize dangers and are therefore exposed to higher risks!

The operating company must ensure the following points:

- The personnel must be commissioned for the activities described in these instructions.
- The staff must be at least 18 years of age and physically and mentally capable.
- The product must be operated only by persons who have undergone appropriate training.
- Personnel must receive regular safety briefings (frequency as per country-specific regulations).
- Work on electrical equipment must be carried out only by qualified electrical specialists.
- Installation, maintenance, and repairs must be carried out only by specialists from J. Schmalz GmbH or by persons who can prove that they have undergone appropriate training at Schmalz.

The following target groups are addressed in these instructions:

- Mechanical and electrical specialists who are responsible for installing, troubleshooting and maintaining the product.

The operator of the system must comply with country-specific regulations regarding the age, ability and training of the personnel.

Valid for Germany:

A qualified employee is defined as an employee who has received technical training and has the knowledge and experience – including knowledge of applicable regulations – necessary to enable him or her to recognize possible dangers and implement the appropriate safety measures while performing tasks. Qualified personnel must observe the pertinent industry-specific rules and regulations.

## 2.6 Personal Protective Equipment

To avoid injury, always use appropriate protective equipment that is suitable for the situation. The protective equipment must meet the following standards:

- Protective work shoes in safety class S1 or higher
- Sturdy work gloves in safety category 2133 or higher
- Industrial helmet
- Ear protection class L or higher
- Eye protection class F
- Hair net
- Closely fitting clothing

## 2.7 Technical Condition

If the product is operated while in a defective state, safety and function will be impaired.

- Only operate the gripper when in perfect working order as originally delivered.
- Follow the maintenance schedule.
- Use only original spare parts from Schmalz.
- If the operating behavior changes, check the gripper for faults. Rectify faults immediately!
- Do not independently modify or alter the gripper.
- Safety features must not be disabled under any circumstances.

Schmalz assumes no liability for consequences of modifications over which it has no control.

## 2.8 Responsibility of the Integrator

The integrator is obligated to perform a risk assessment for the environmental conditions at the installation location.

The integrator is also responsible for third parties in the working area of the gripper. The operating company must ensure that they have the appropriate qualifications and skills.

- Ensure that regular breaks are taken.
- Ensure that the gripper cannot be started up by unauthorized persons.
- During maintenance or repair work, ensure that the gripper cannot be operated.
- Clearly define the responsibilities for the various activities performed with the gripper.
- Ensure that these responsibilities are observed.
- When handling unfamiliar loads, carry out tests where necessary to ensure safe operation:
  - The load is sufficiently rigid that it cannot be damaged during handling.

## 2.9 Country-Specific Regulations for the Operating Company

1. Observe the country-specific regulations regarding accident prevention, safety testing and environmental protection.
2. The gripper is to be used in combination with an automated handling system (gantry/robot). Ensure that the appropriate country-specific regulations and safety regulations are adhered to.

## 3 Product Description

### 3.1 Description of the Gripper

Gripping systems use a vacuum to lift defined products. One or more workpieces of different sizes can be lifted. The gripping system achieves its maximum load-bearing capacity when all the suction cups or the sealing foam are placed on an airtight workpiece with a smooth surface.

The handling system is responsible for the motion in the various axes (robot/gantry). The gripper is connected to the handling system through the integrated threaded bushes or special robot flanges (> See ch. Accessories).

The gripper FQE is available in three basic technical designs:

- Version FQE ... M, for an external vacuum supply
- Version FQE ... Xb, with internal vacuum generation
- Version FQE ... Xc, with internal vacuum generation and control of "suction" and "blow-off"

Each gripper is individual thanks to its customized design. Therefore, the grippers differ in detail in terms of the size of the suction area, the number of vacuum generators (SEP), the arrangement and design of the suction cups or suction cells in the sealing plate, the flow restrictors, etc.

### 3.2 FQE ... M

The gripper is supplied by an external vacuum. The connections for measuring the vacuum and for external blow-off are available for optional use.

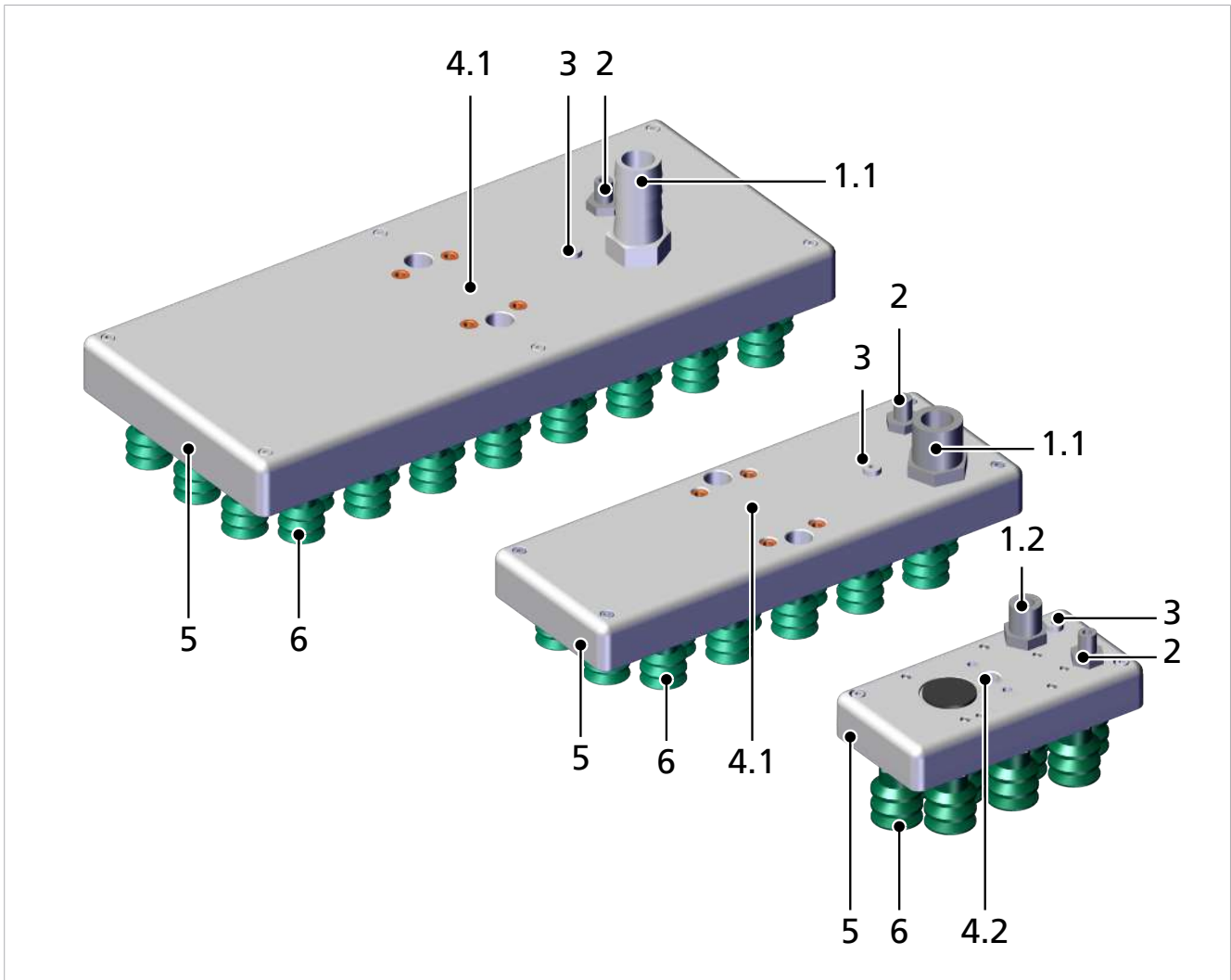

1.1	1/2" vacuum connection	1.2	1/4" vacuum connection
2	1/8" vacuum measurement connection	3	M5 blow-off pulse connection
4.1	Mechanical connection, 2x 1/4" and 4x M5	4.2	Mechanical connection, 1x 1/8" and 2x M5
5	Suction trough	6	Suction plate, with suction cups or with sealing foam

### 3.3 FQE ... Xb

Depending on the configuration, the gripper is equipped with one to three vacuum generators (SEP nozzles). The connections for measuring the vacuum and for an external blow-off pulse are available for optional use.

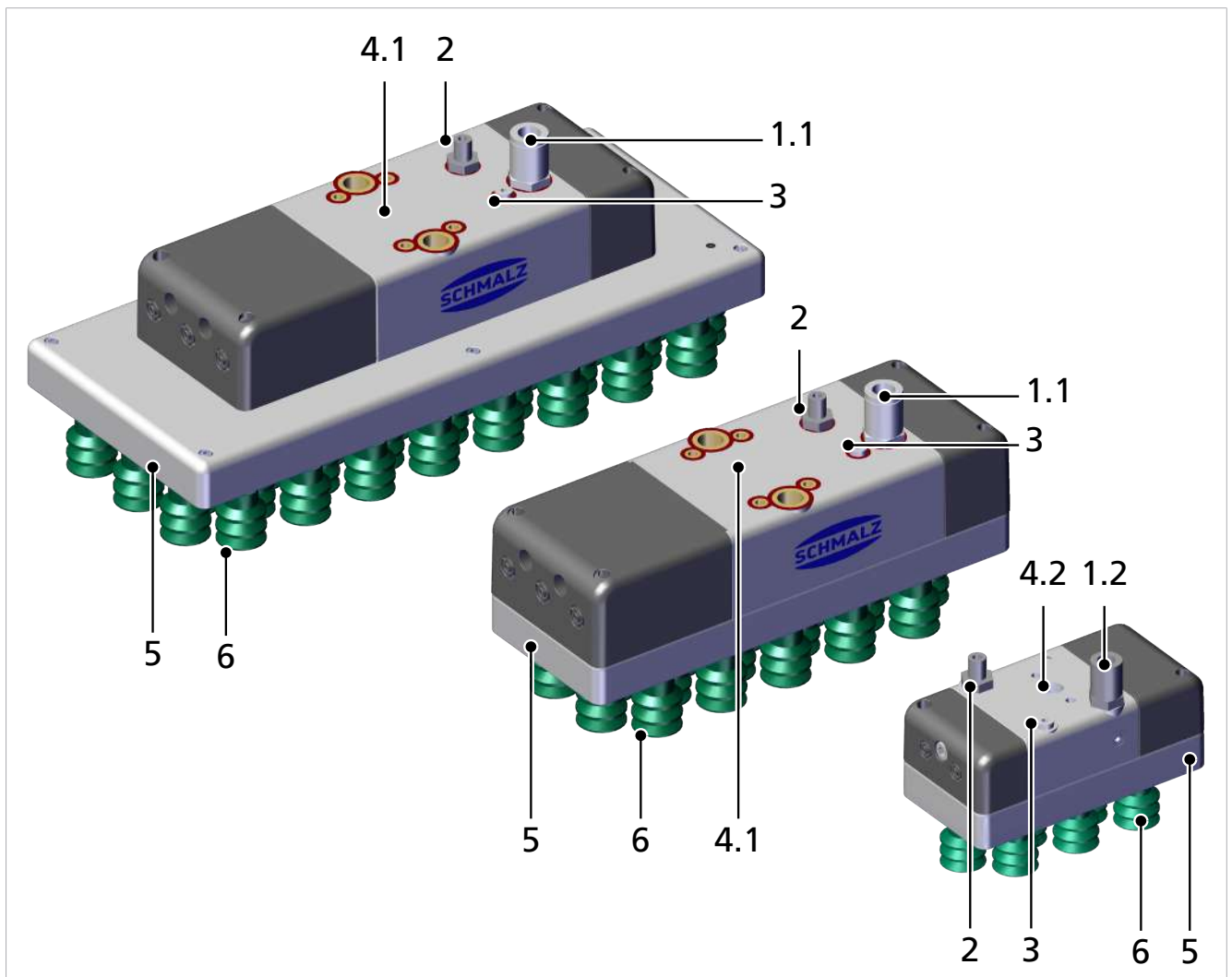

1.1	1/4" compressed air connection
2	1/8" vacuum measurement connection
4.1	Mechanical connection, 2x 1/4" and 4x M5
5	Suction trough

1.2	1/8" compressed air connection
3	M5 blow-off pulse connection
4.2	Mechanical connection, 1x 1/8" and 2x M5
6	Suction plate, with suction cups or with sealing foam

### 3.4 FQE ... Xc

Depending on the configuration, the gripper is equipped with one to three vacuum generators (SEP nozzles). The connections for measuring the vacuum and for an external blow-off pulse are available for optional use. "Suction" and "blow-off" can be controlled via the integrated valves.

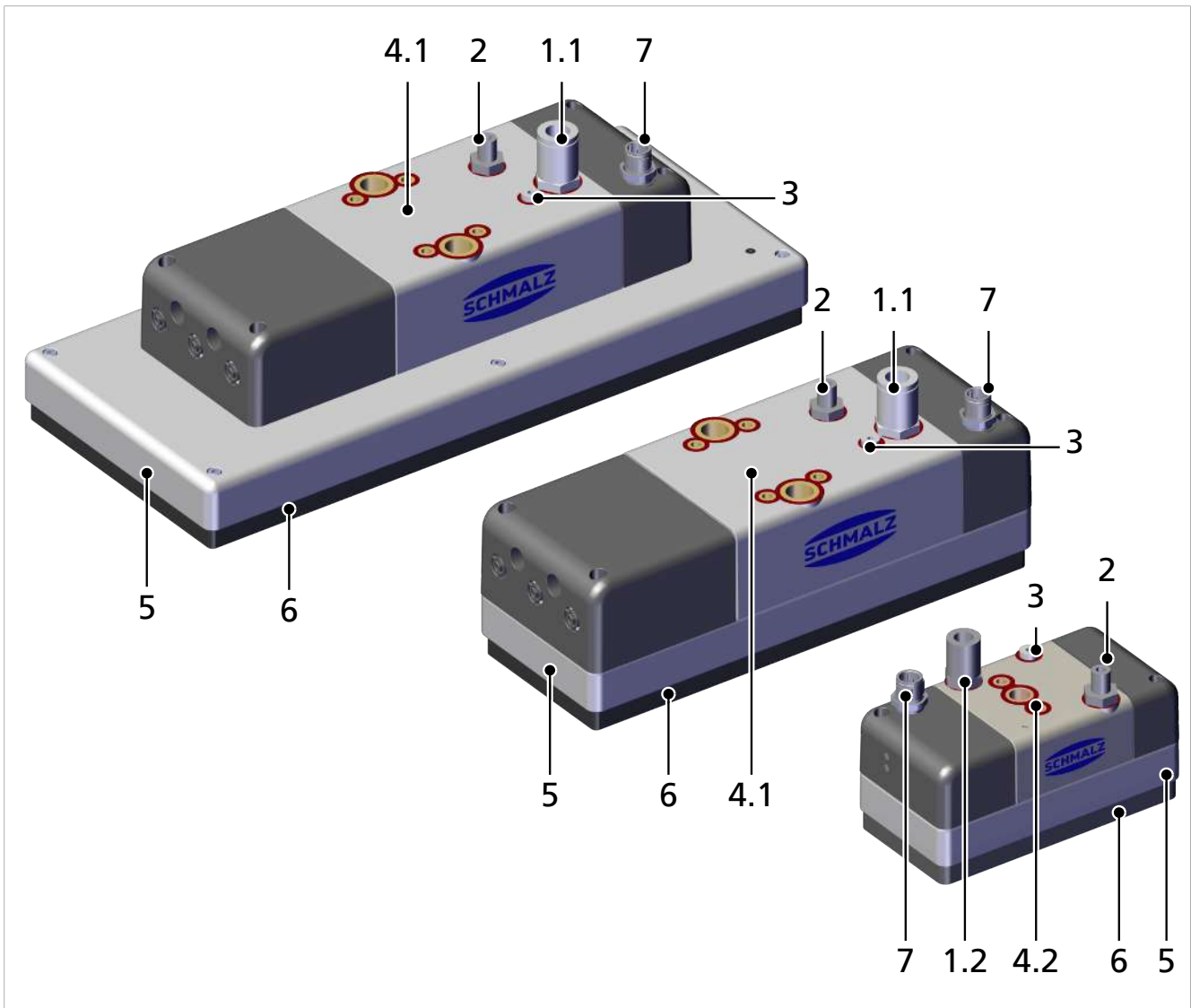

1.1	1/4" compressed air connection	1.2	1/8" compressed air connection
2	1/8" vacuum measurement connection	3	M5 blow-off pulse connection
4.1	Mechanical connection, 2x 1/4" and 4x M5	4.2	Mechanical connection, 1x 1/8" and 2x M5
5	Suction trough	6	Suction plate, with suction cups or with sealing foam
7	M12-5 electrical connection		

## 4 Technical Data

### 4.1 General Parameters

Parameter	Gripper type			Unit
	FQE ... M	FQE ... Xb	FQE ... Xc	
Number of suction points	Based on the configuration – see order confirmation			
Operating pressure	3.0 – 6.0			bar
Maximum degree of evacuation (at opt. input pressure)	90***	670 (gripper size of 120x60 mm, 2 vacuum modules) 610 (gripper size of 220x80 and 300x130 mm, 2 or 3 vacuum modules)		mbar
Optimal input pressure	—	5.0		bar
Compressed air consumption *	—	45 to 250 (depending on the number and size of the SEP nozzles)		l/min
Max. suction rate	—	50 to 380 (depending on the number and size of the SEP nozzles; see the order confirmation)		l/min
Permissible lift capacity **	70 (gripper size of 120x60 mm) 160 (gripper size of 220x80 mm) 350 (gripper size of 300x130 mm)			N
Sound level at full coverage	—	64.1 (gripper size of 120x60 mm) 62.7 (gripper size of 220x80 mm) 64.6 (gripper size of 300x130 mm)		dB(A)
Operating voltage	24			V DC
Permitted temperature range	5 to +60 (with sealing foam) -20 to +60 (with suction cups)	5 to +50		° C
Foam/suction cup grid	Based on the configuration – see order confirmation			
Weight	Based on the configuration – see order confirmation			

\* Compressed air provided by the customer: Dry and filtered air in accordance with ISO 8573-1:2010 [7:4:4]

\*\* Depending on the suction element and vacuum, the lift capacity cannot be reached or exceeded!

\*\*\* Dependent on the vacuum generator but not above 90%

**Tool Center Point (TCP) and Center of Gravity (COG)**

**Typ /type**

		<b>Greifergröße / Gripper dimensions [mm]</b>					
		120x60		220x80		300x130	
Schaum / foam	TCP [mm]	X	0	X	0	X	0
		Y	0	Y	0	Y	0
		Z	80	Z	80	Z	85
Push-in Sauger / push-in suction cups	COG [mm]	X	0	X	0	X	0
		Y	0	Y	15	Y	10
		Z	40	Z	40	Z	50
Gewicht/ weight [Kg]		0,63		0,95		1,35	
Einschraubsauger / screw in suction cups	TCP [mm]	X	0	X	0	X	0
		Y	0	Y	0	Y	0
		Z	100	Z	95	Z	100
	COG [mm]	X	0	X	0	X	0
		Y	0	Y	10	Y	10
		Z	40	Z	45	Z	55
Gewicht/ weight [Kg]		0,65		1,01		1,52	
	TCP [mm]	X	0	X	0	X	0
		Y	0	Y	0	Y	0
		Z	105	Z	100	Z	105
	COG [mm]	X	0	X	0	X	0
		Y	0	Y	10	Y	10
		Z	45	Z	50	Z	60
Gewicht/ weight [Kg]		0,7		1,2		1,92	

The information provided here is for an FQE Xc gripper with a flange for UR.



## 4.2 Dimensions

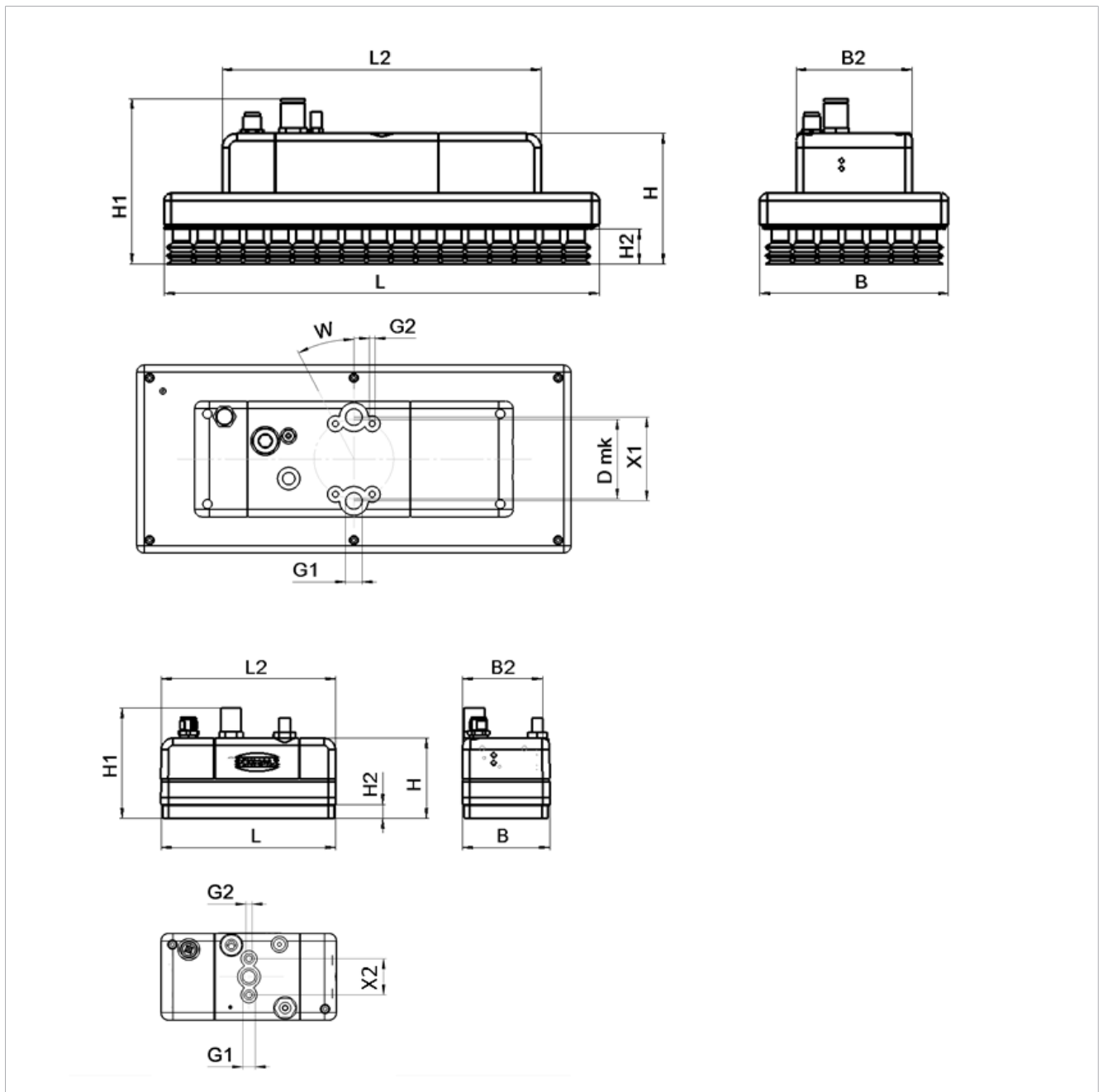

	L	L2	B	B2	H	H1*	H2	G1	G2	Dmk	W	X1	X2
FQE 120x60, sealing foam	120	120.1	60	60	55	75.7	10	1/8"	M5	—	—	—	25
FQE 120x60, screw-in suction cup	120	120.1	60	60	76.3	97	31.3	1/8"	M5	—	—	—	25
FQE 120x60, plug-in suction cup	120	120.1	60	60	69.3	90	24.3	1/8"	M5	—	—	—	25
FQE 220x80, sealing foam	220	220.5	80	80.5	70	94	10	1/4"	M5	55	27.5°	58	—

FQE 220x80, screw-in suc- tion cup	220	220.5	80	80.5	91.3	115.3	31.3	1/4"	M5	55	27.5°	58	—
FQE 220x80, plug-in suc- tion cup	220	220.5	80	80.5	84.3	108.3	24.3	1/4"	M5	55	27.5°	58	—
FQE 300x130, sealing foam	300	220.5	130	80.5	70	94	10	1/4"	M5	55	27.5°	58	—
FQE 300x130, screw-in suc- tion cup	300	220.5	130	80.5	91.3	115.3	31.3	1/4"	M5	55	27.5°	58	—
FQE 300x130, plug-in suc- tion cup	300	220.5	130	80.5	84.3	108.3	24.3	1/4"	M5	55	27.5°	58	—

\* H1 is provided as an example and varies based on the configuration

### 4.3 Pneumatic Circuit Diagram (Version FQE ... Xc)

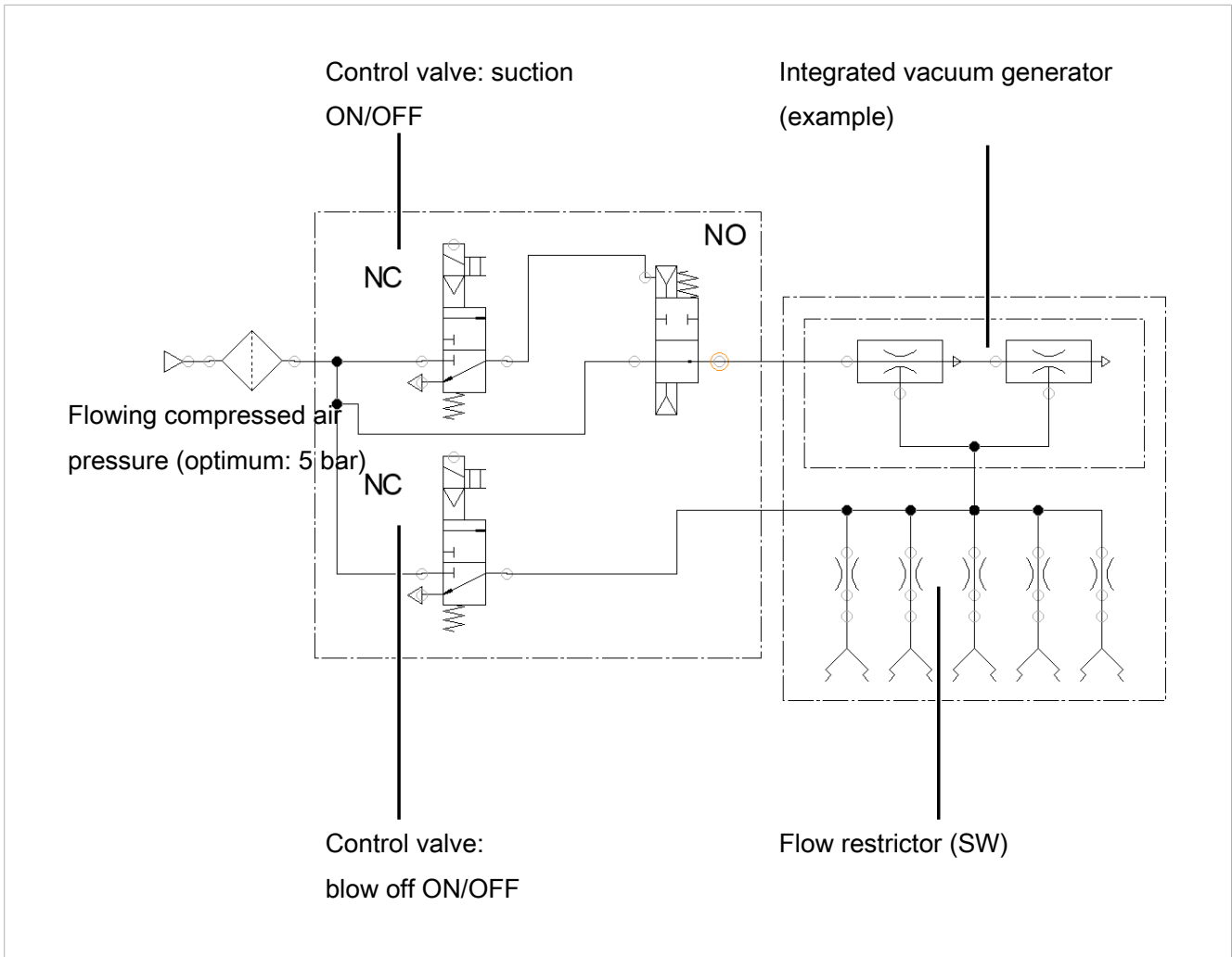

#### 4.4 Circuit Diagram for Valves (Version FQE ... Xc)

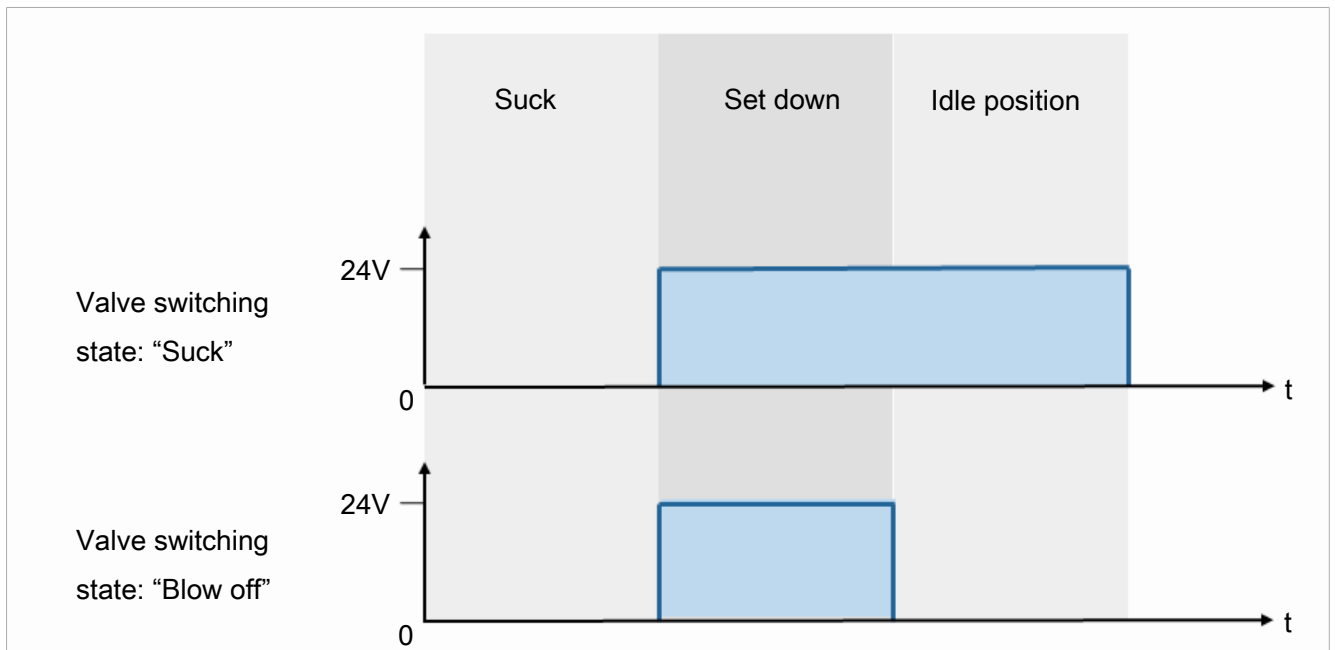

### 4.5 Display Elements (Version FQE ... Xc)

With the gripper version FQE ... Xc, the "suction" and "blow-off" process states are each assigned an LED.

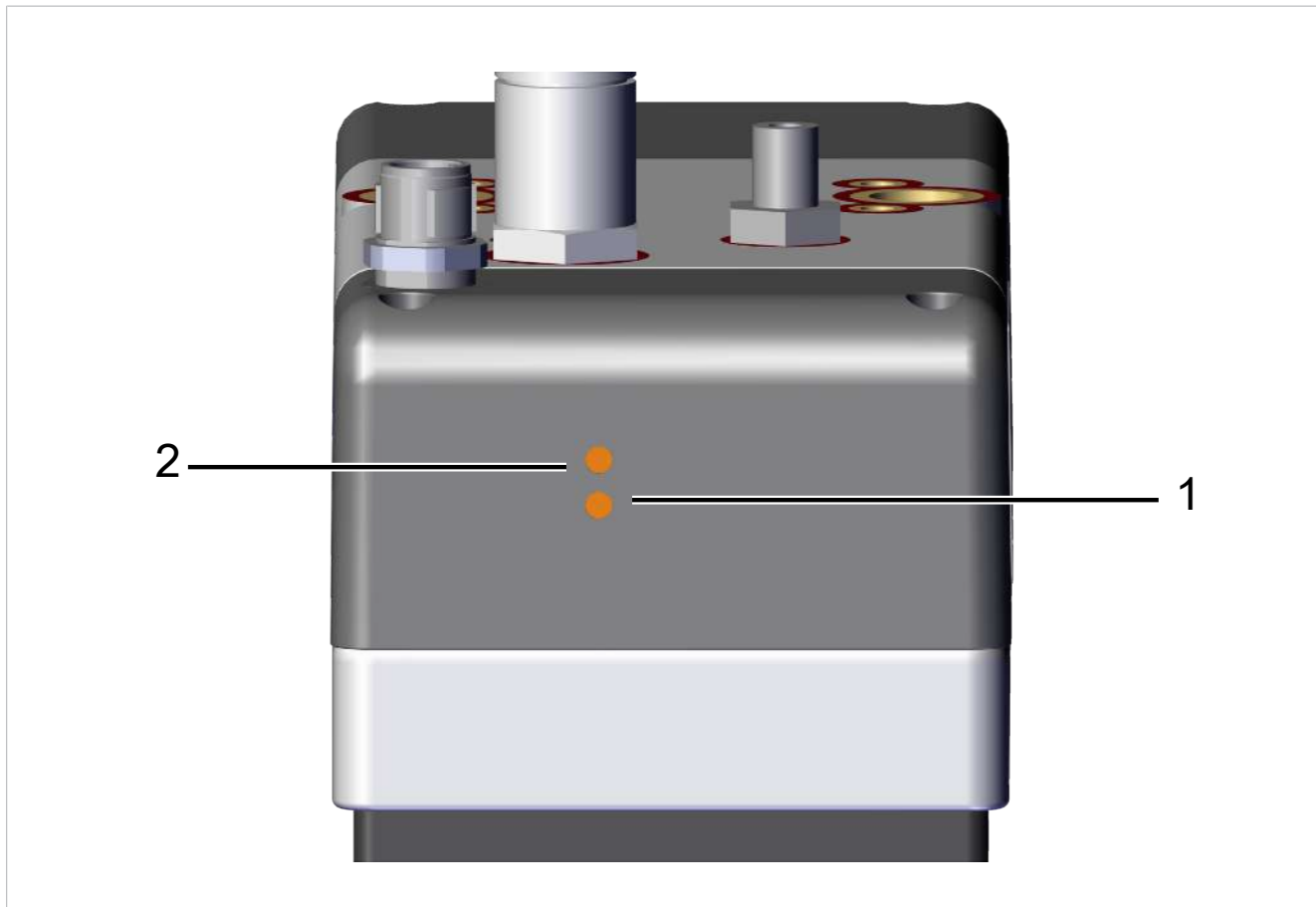

Item	Meaning	State	Description
1	Suction LED	Lit up	"Suction" OFF
		OFF	"Suction" ON (transport workpiece)
2	Blow-off LED	Lit up	"Blow-off" ON (deposit workpiece)
		OFF	"Blow-off" OFF

## 5 Transport and Storage

### 5.1 Checking the Delivery

The scope of delivery can be found in the order confirmation. The weights and dimensions are listed in the delivery notes.

1. Compare the entire delivery with the supplied delivery notes to make sure nothing is missing.
2. Damage caused by defective packaging or occurring in transit must be reported immediately to the carrier and J. Schmalz GmbH.

### 5.2 Reusing the Packaging

The product is delivered in cardboard packaging. The packaging should be reused to safely transport the product at a later stage.



Keep the packaging for future transport or storage.

## 6 Installation

### 6.1 Installation Instructions



#### ⚠ CAUTION

##### Improper installation or maintenance

Personal injury or damage to property

- ▶ Prior to installation and before maintenance work, the product must be disconnected from the power supply, depressurized (vented to the atmosphere) and secured against unauthorized restart.

The gripper FQE may be installed in any position.

The grippers FQE can be mechanically connected as follows:

- Via the mounting holes in the housing (> See ch. Dimensions)
- Via the robot-specific connection sets (ROB-SET) that can be chosen during configuration
- Via various accessory parts such as a connecting plate, spring plunger, ball joint, Flexolink, etc.(> See ch. Accessories)

### 6.2 Mechanical Attachment

#### Mounting the FQE on the robot using ROB-SETs:

The robot is selected while configuring the gripper FQE. The flange module is mounted on the gripper at the factory. The flange plate is supplied loose and mounted on the robot by the customer.

The design of the flange module varies depending on the size of the gripper. The figure below shows the 120x60 mm gripper.

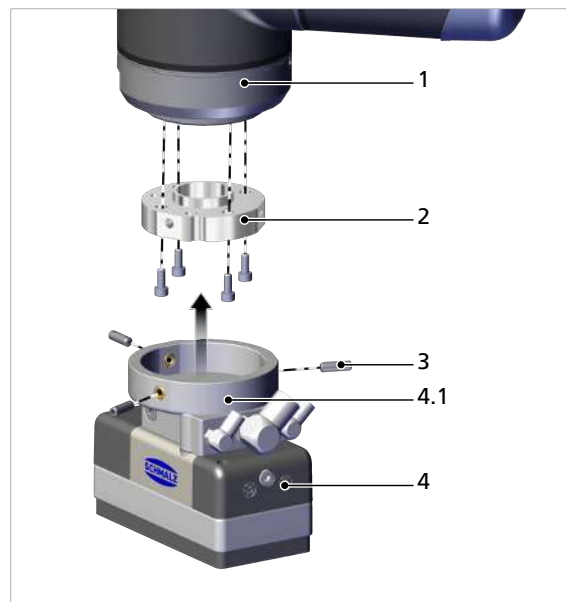

1. Mount the flange plate (2) on the robot (1)

2. Attach the gripper (4) onto the flange plate (2) via the flange module mounted at the factory (4.1)

3. Fit the gripper to the flange plate using threaded pins M5x16 (3). The threaded pins should not protrude.

**Mounting the FQE directly on the mounting holes on the gripper:**

It is connected to the upper part of the housing using 1x 1/8" and 2x M5 (gripper size of 120x60 mm) or 2x 1/4" and 4x M5 (gripper sizes of 220x80 mm and 300x130 mm) (> See ch. Dimensions).

**Mounting the FQE on the mounting holes on the gripper using accessory parts such as connecting plates and spring plungers (> See ch. Accessories):**

The components for this type of connection are available as accessories for the respective gripper sizes.

- Connecting plates can be used to mechanically connect two to four grippers.
- Depending on the version, the connection elements have a connection thread of 1/8", 1/4" and 1/2" that allows them to be adapted to the Schmalz spring plunger.
- The connection and adapter plates are supplied with the screws required for mounting.
- The customer is responsible for choosing the appropriately sized connection (application, transported load).

The spring plungers are to be positioned as far out as possible on the block-mounted grippers. An example for mounting 220x80 mm grippers on blocks is provided below.

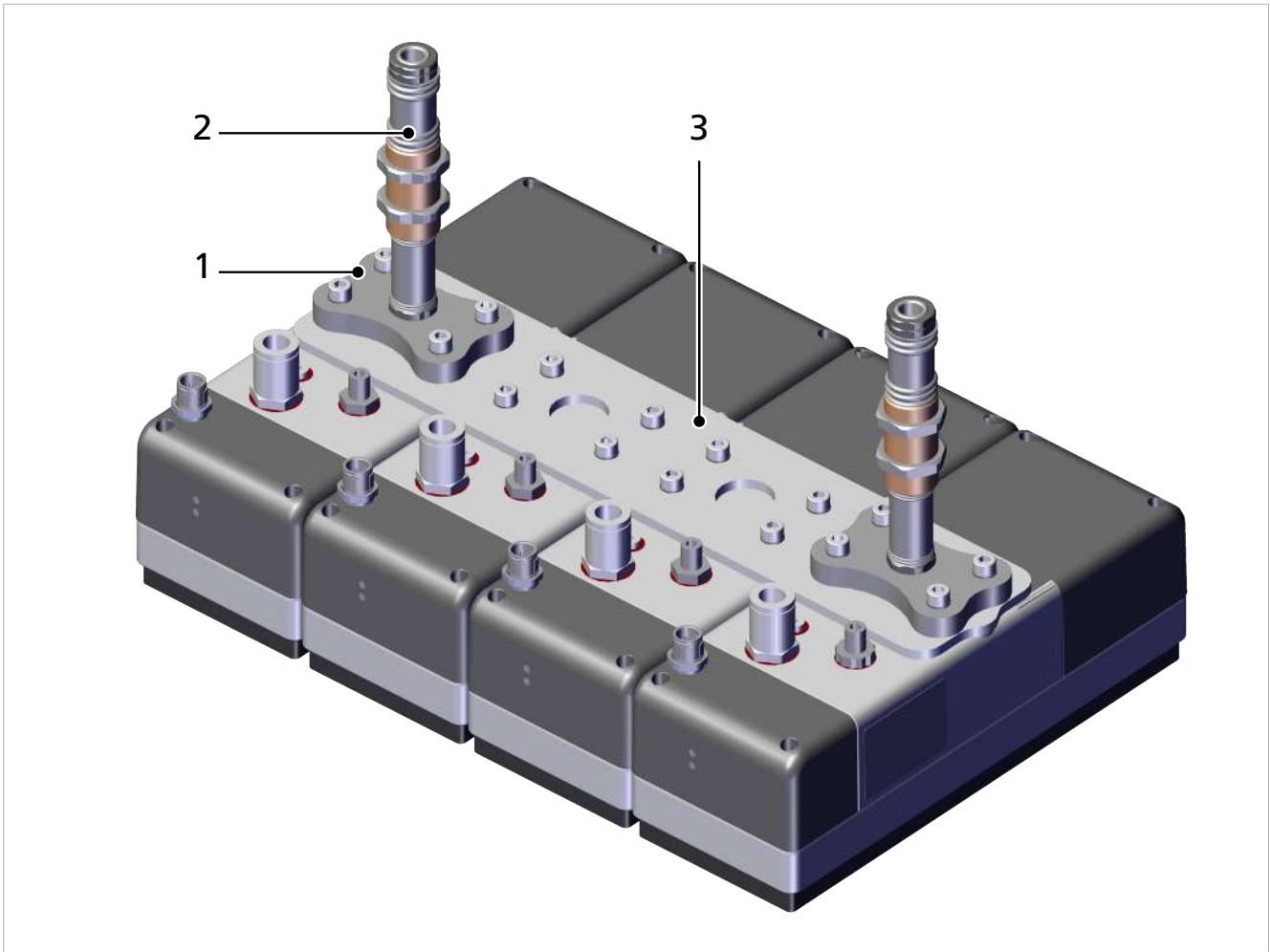

1 Adapter plate  
(220x80 and 300x130 gripper sizes only)  
3 Connecting plate

2 Spring plunger



## Notes on the adapter plate

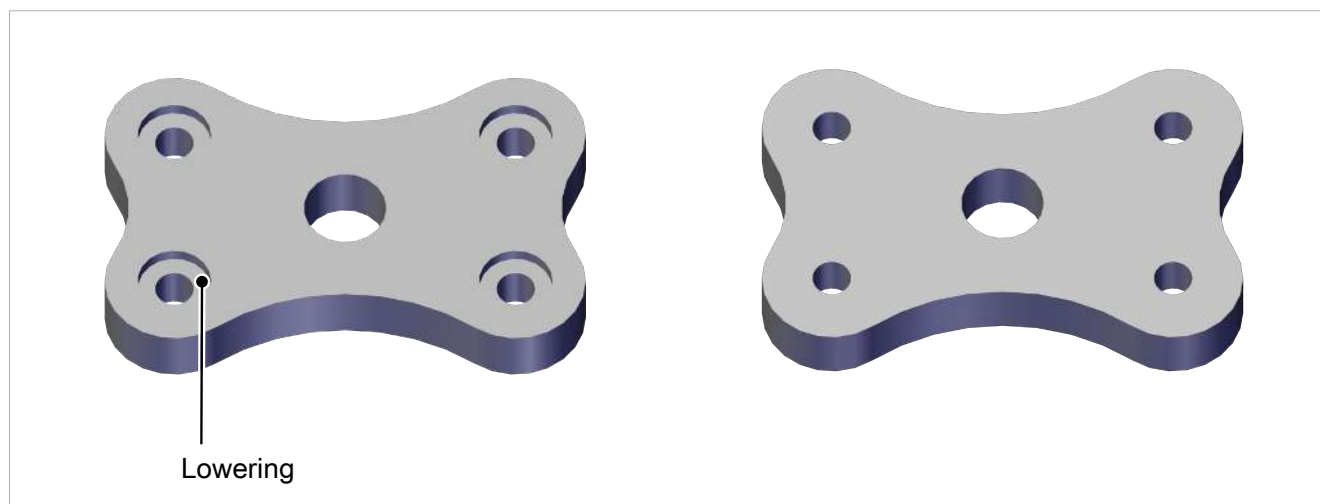

1. The adapter plate is used only in combination with the 220x80 and 300x130 gripper sizes
2. The boreholes on the adapter plate are sunken on one side.  
 With the 220x80 gripper size, the adapter plates must be set onto the connecting plates such that the sunken side is pointing downwards (towards the gripper; otherwise, the supplied screw is too long).  
 With the 300x130 gripper size, the adapter plates must be set onto the connecting plates such that the sunken side is pointing upwards (away from the gripper; otherwise, the supplied screw is too short).

### 6.3 Electrical Connection



#### **⚠ DANGER**

#### **Electric shock from touching live components**

Serious injury or death!

- ▶ Make sure that the electrical components are not live before installation, maintenance and troubleshooting.
- ▶ Switch off the mains switch and secure against unauthorized restart.

The gripper types FQE ... M and FQE ... Xb do not have electrical connections.  
 With the gripper type FQE ... Xc, the integrated valves are activated via an M12-5 plug.

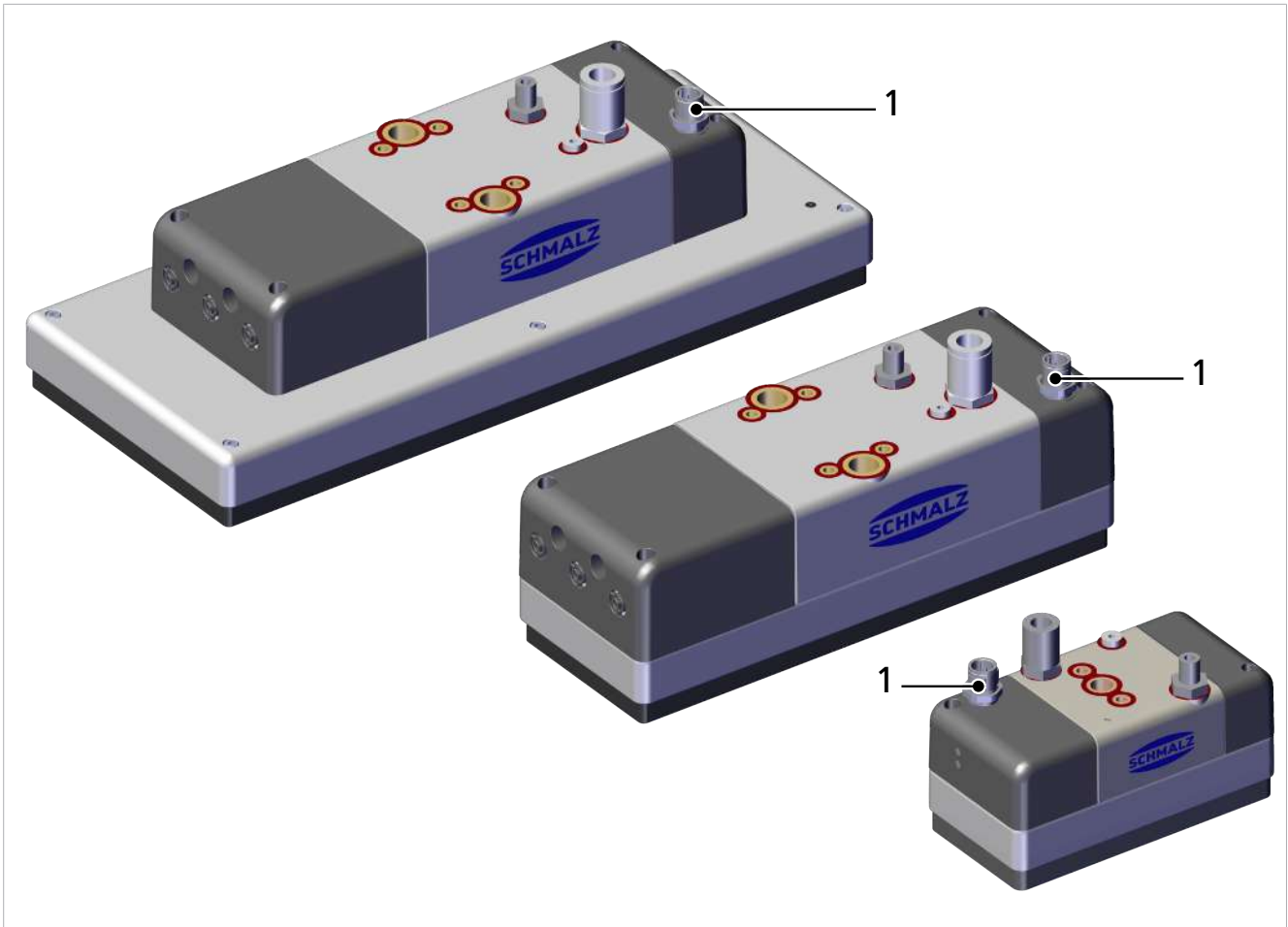

1 M12-5 electrical connection

PNP version:

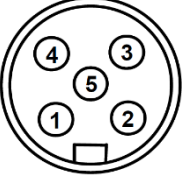
M12 connector	Pin	Litz wire color	Function
	1	Brown	Not used
	2	White	Blow-off valve "On"
	3	Blue	Ground
	4	Black	Suction valve "Off"
	5	Gray	Not used

NPN version:

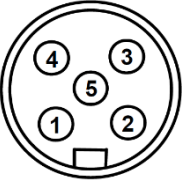
M12 connector	Pin	Litz wire color	Function
	1	Brown	24 V
	2	White	Blow-off valve "On"
	3	Blue	Not used
	4	Black	Suction valve "Off"
	5	Gray	Not used

## 6.4 Pneumatic connection

1. Shorten the hoses and pipelines as much as possible.
2. Keep hose lines free of bends and crimps.
3. Lay hose lines in such a way that they do not rub.

Ensure that the hose lines have the appropriate dimensions.



### CAUTION

#### **Compressed air or vacuum in direct contact with the eye**

Severe eye injury

- ▶ Wear eye protection
- ▶ Do not look into compressed air openings
- ▶ Do not look into the silencer air stream
- ▶ Do not look into vacuum openings, e.g. suction cups

The gripper type FQE ... M is supplied with an external vacuum. The gripper types FQE ... X come with integrated vacuum generators (SEP nozzles).

The vacuum can be monitored on connection 2 (e.g. using a vacuum switch (> See ch. Accessories)).

To ensure that the workpiece is deposited quickly, an external blow-off pulse can be provided via connection 3. In the case of the gripper FQE ... Xc, a blow-off pulse can be provided via the control.

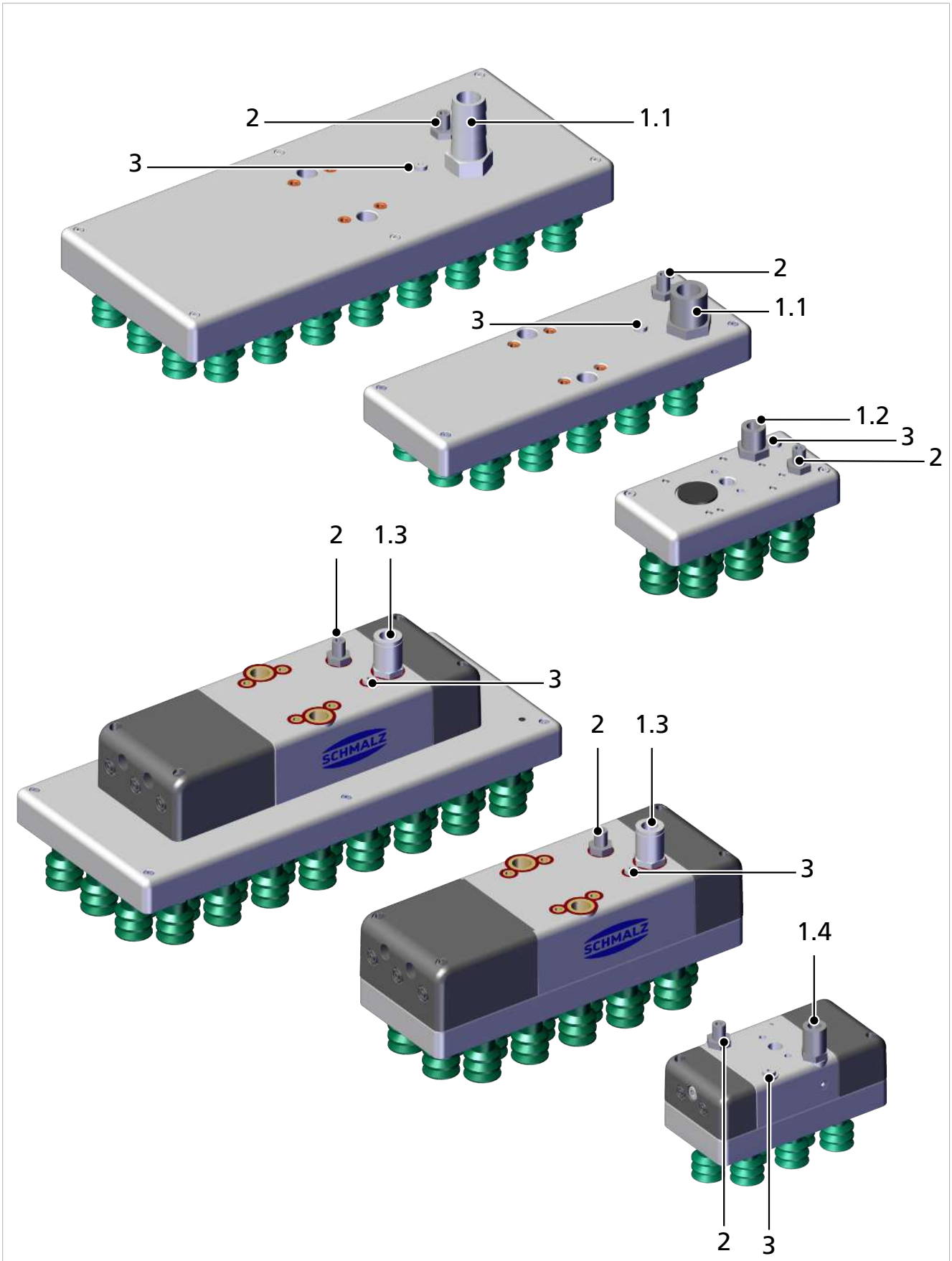

1.1	1/2" vacuum connection	1.2	1/4" vacuum connection
1.3	1/4" compressed air connection	1.4	1/8" compressed air connection
2	1/8" vacuum measurement connection	3	M5" blow-off pulse connection

## 7 Start of Operations

### 7.1 Personnel Qualification

Unqualified personnel cannot recognize dangers and are therefore exposed to higher risks!

1. Only instruct qualified personnel to perform the tasks described in these operating instructions.
2. The product may only be operated by persons who have undergone appropriate training.
3. Electrical work and installations may only be carried out by qualified electrical specialists.
4. Assembly and maintenance work must only be carried out by qualified personnel.

### 7.2 Before Initial Start of Operations

Before the initial start of operations following the installation, repair, servicing or maintenance work, you must check the following:

- All mechanical connectors are properly attached and secured.
- All screws and nuts are tightened to specified torques.
- All components are installed.
- The safety distances have been maintained.
- The electrical cable and supply hoses are properly routed.
- The EMERGENCY STOP switch for the overall system is working.
- The type plate is clearly legible.



#### **⚠ DANGER**

##### **Electric shock from touching live components**

Serious injury or death!

- ▶ Make sure that the electrical components are not live before installation, maintenance and troubleshooting.
- ▶ Switch off the mains switch and secure against unauthorized restart.



#### **⚠ CAUTION**

##### **Noise pollution due to incorrect installation of the pressure and vacuum connections**

Hearing damage

- ▶ Correct installation.
- ▶ Wear ear protectors.



#### **⚠ CAUTION**

##### **Vacuum close to the eye**

Severe eye injury!

- ▶ Wear eye protection.
- ▶ Do not look into vacuum openings, e.g. suction cups.





## ⚠ CAUTION

### Risk of crushing if the suction cup is abruptly attached to a workpiece

- ▶ Do not place any body parts between the suction cup and the workpiece

#### Handling procedure

1. Placement of the gripper on the workpiece
  - Optimally position the gripper on the workpiece (centrally/on the center of gravity)
  - Suction cups must be compressed by 50% of the suction cup stroke
2. Generate or establish vacuum
  - M version: apply vacuum on the vacuum connection
  - Xb version: apply compressed air on the compressed air connection
  - Xc-Version: compressed air must be applied at the compressed air connection. In addition, the appropriate control valve must be activated (> See ch. Pneumatic Circuit Diagram).
3. Movement of the gripper after reaching the pre-set vacuum value
4. Lower workpieces onto clear, even surfaces
5. Only switch off the vacuum when the workpiece rests completely and safely on a secure surface
  - When switching off the device, the suction cups are automatically ventilated
  - Optionally, a blow-off pulse can be produced at the compressed air connection.
6. Depending on the gripper version, switch off the compressed air, vacuum or valves.

 Druckluft  
 Vakuum

FQE X

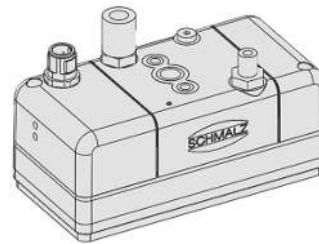

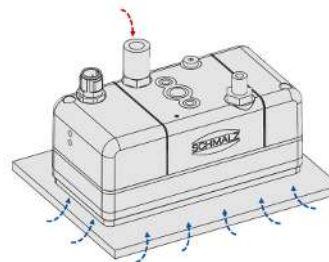

FQE X  
Ansaugen

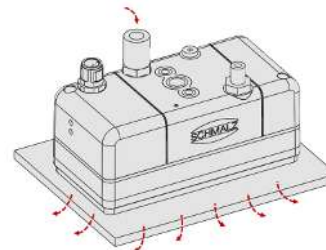

FQE X  
Ablegen



c version: switch off compressed air via the valve  
b version: switch off compressed air externally

 Druckluft  
 Vakuum

FQE M

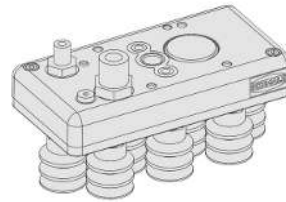

FQE M  
Ansaugen

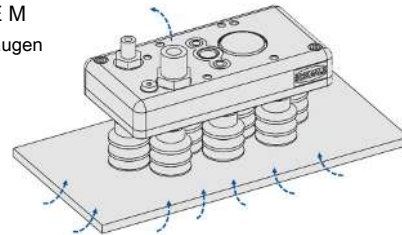

FQE M  
Ablegen

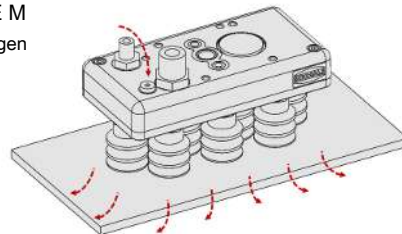

Use an external blow-off pulse to deposit workpieces more quickly.

## 8 Operation

### 8.1 Preparations

- ▶ The product must be operated only by persons who have undergone appropriate training.

To avoid injury, always use appropriate protective equipment that is suitable for the situation. The protective equipment must meet the following standards:

- Protective work shoes in safety class S1 or higher
- Ear protection class L or higher
- Sturdy work gloves in safety category 2133 or higher
- Eye protection class F



#### **WARNING**

##### **Extraction of hazardous media, liquids or bulk material**

Personal injury or damage to property!

- ▶ Do not extract harmful media such as dust, oil mists, vapors, aerosols etc.
- ▶ Do not extract aggressive gases or media such as acids, acid fumes, bases, biocides, disinfectants or detergents.
- ▶ Do not extract liquids or bulk materials, e.g. granulates.

Before each activation of the gripping system, the following measures must be taken:

1. Check the device for visible damage. Correct any faults or report them to the supervising personnel.
2. Ensure that only authorized persons are present in the working area of the machine or system in order to prevent any hazard from switching on the machine.
3. Ensure that the danger zone of the machine or system is free of persons during automatic operation in non-HRC applications.



#### **WARNING**

##### **Applications with collaborative robots:**

##### **Insufficient vacuum generation or insufficient coverage of the gripper.**

##### **The load drops immediately.**

Risk of injury from falling load!

- ▶ The operator must be separated from the handling area of the load by a secure barrier.



## 9 Troubleshooting

### 9.1 Safety

Maintenance work may only be carried out by qualified personnel.



#### **WARNING**

##### **Risk of injury due to incorrect maintenance or troubleshooting**

- ▶ Check the proper functioning of the product, especially the safety features, after every maintenance or troubleshooting operation.



#### **CAUTION**

##### **Improper installation or maintenance**

Personal injury or damage to property

- ▶ Prior to installation and before maintenance work, the product must be disconnected from the power supply, depressurized (vented to the atmosphere) and secured against unauthorized restart.

## 9.2 Faults, Causes, Solutions

Fault	Possible cause	Solution
Vacuum level is not reached or vacuum is created too slowly	Leakage Wear Dirt Incorrect installation	Check the vacuum generator and, where applicable, the compressed air supply (input pressure) (defective/dirty/installed correctly?)
		Check the hose connections (tight fit, hose has no faults or kinks)
		Check the seals (between the suction trough and suction plate)
		When using suction cups --> check whether flow restrictors are pressed in or screwed in (if the openings are too large, the vacuum generator power may be insufficient)
		Clean the dust filter if necessary
		Replace worn sealing mat/suction cup Internal diameter of compressed air/vacuum hoses too low (note when retrofitting the gripper – e.g. with larger or extra flow restrictors or adding additional SEP nozzles)
Load cannot be held	Vacuum level too low	See above for possible causes
	Suction force insufficient/workpiece too heavy	Increase the vacuum where applicable or use additional grippers. Observe the max. permissible lift capacity (> See ch. General Parameters)
	Flow restrictors are dirty	Clean the flow restrictors
	Gripper contact force on the workpiece is too low	Press the area grippers more firmly Recommendation: on even surfaces, compress the foam and suction cups by 50%
	Too short retention time for the gripper on the workpiece to be lifted	Extend the retention time while picking up the workpiece
	Too fast or jerky lifting of workpieces	Optimize the motion and avoid peaks in acceleration
	The workpieces to be lifted are not suitable for the gripper (e.g. non-rigid)	Use a different gripping system. If necessary, switch from foam to suction cups
	Flow restrictors are too small	With air-permeable workpieces, a larger flow restrictor may need to be used. Replace the sealing plate
Sealing mat wears out very quickly	The suction cup is angled or makes a grinding noise when applied to the workpiece to be lifted	Set it down vertically on the workpiece
Version FQE Xc: The activation of the valves does not work	Electrical control is not working	Check connections. Input signals correct?
	Solenoid valve is defective	Please contact the J.Schmalz GmbH customer service team

## 10 Maintenance

### 10.1 Safety

Maintenance work may only be carried out by qualified personnel.



#### **WARNING**

##### **Risk of injury due to incorrect maintenance or troubleshooting**

- ▶ Check the proper functioning of the product, especially the safety features, after every maintenance or troubleshooting operation.



#### **CAUTION**

##### **Improper installation or maintenance**

Personal injury or damage to property

- ▶ Prior to installation and before maintenance work, the product must be disconnected from the power supply, depressurized (vented to the atmosphere) and secured against unauthorized restart.

## 10.2 Maintenance Schedule



Schmalz stipulates the following checks and check intervals. The operator must comply with the legal regulations and safety regulations applicable at the location of use. These intervals apply to single-shift operation. For heavier use, such as multi-shift operation, the intervals must be shortened accordingly.

Maintenance task	Daily	Weekly	Monthly	Every six months	Yearly
Check if the vacuum generator generates unusual noise under full load		X			
Check connections on flange for secure fit – machine screws with wedge lock washers for attachment of the flange to the suction spider		X			
Check the suction cup and foam for wear, tears and leaks. Replace if necessary.		X			
Check the ejectors for dirt and clean if necessary			X		
Check the condition of the vacuum hoses (not brittle, no kinks, no chafe marks).			X		
Check all load-bearing parts (e.g. suspension) for deformation, wear or other damage.			X		
Leak test			X		
Is the electrical installation still OK? Is the cable screw union secure?				X	
Check that all the connections are secure, e.g. the screws, hose clamps, etc.				X	
Check the legibility of the type plate and clean it if necessary.					X
The operating instructions are available, legible, and can be accessed by personnel.					X
Check the general condition of the device.					X

## 10.3 Cleaning the Gripper

1. For cleaning, do not use aggressive cleaning agents such as industrial alcohol, white spirit or thinners. Only use cleaning agents with pH 7–12.
2. Remove dirt on the exterior of the device with a soft cloth and soap suds at a maximum temperature of 60° C. Make sure that the silencer is not soaked in soapy water.
3. Ensure that no moisture can reach the electrical connection or other electrical components.

## 10.4 Removing the Ejector Module

The following disassembly steps apply to all sizes of the versions FQE ... Xb / Xc.

- ▶ Unscrew the fastening screws

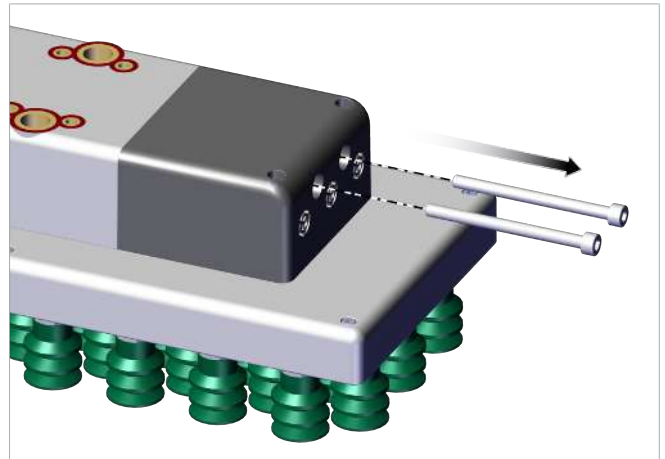

- ▶ Remove the silencer cap

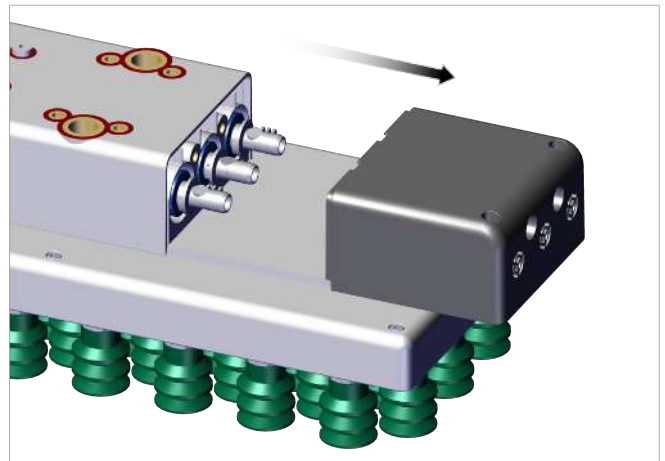

1. Pull out the ejector module (2 or 3 pieces)

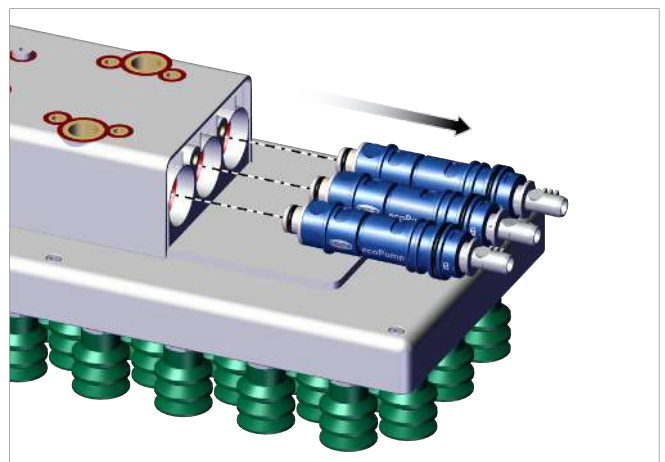

2. For further cleaning of the ejector module, refer to operating instructions 30.30.01.00600 (> See ch. Other Applicable Documents).

During assembly, ensure the silencer cap is properly fitted on the basic module.

## 10.5 Disassembling and Cleaning the Silencer Inserts

The following steps apply to all sizes of the versions FQE ... Xb / Xc

- ▶ Depending on the version, remove the one to four silencer sections from the silencer cap

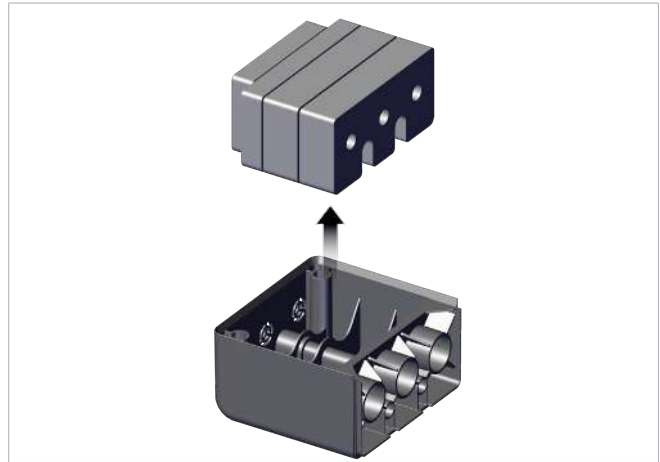

The silencer sections can be cleaned with a soft brush.

## 10.6 Removing the Sealing/Suction Plate

The following steps apply to all sizes of the versions FQE ... Xb / Xc

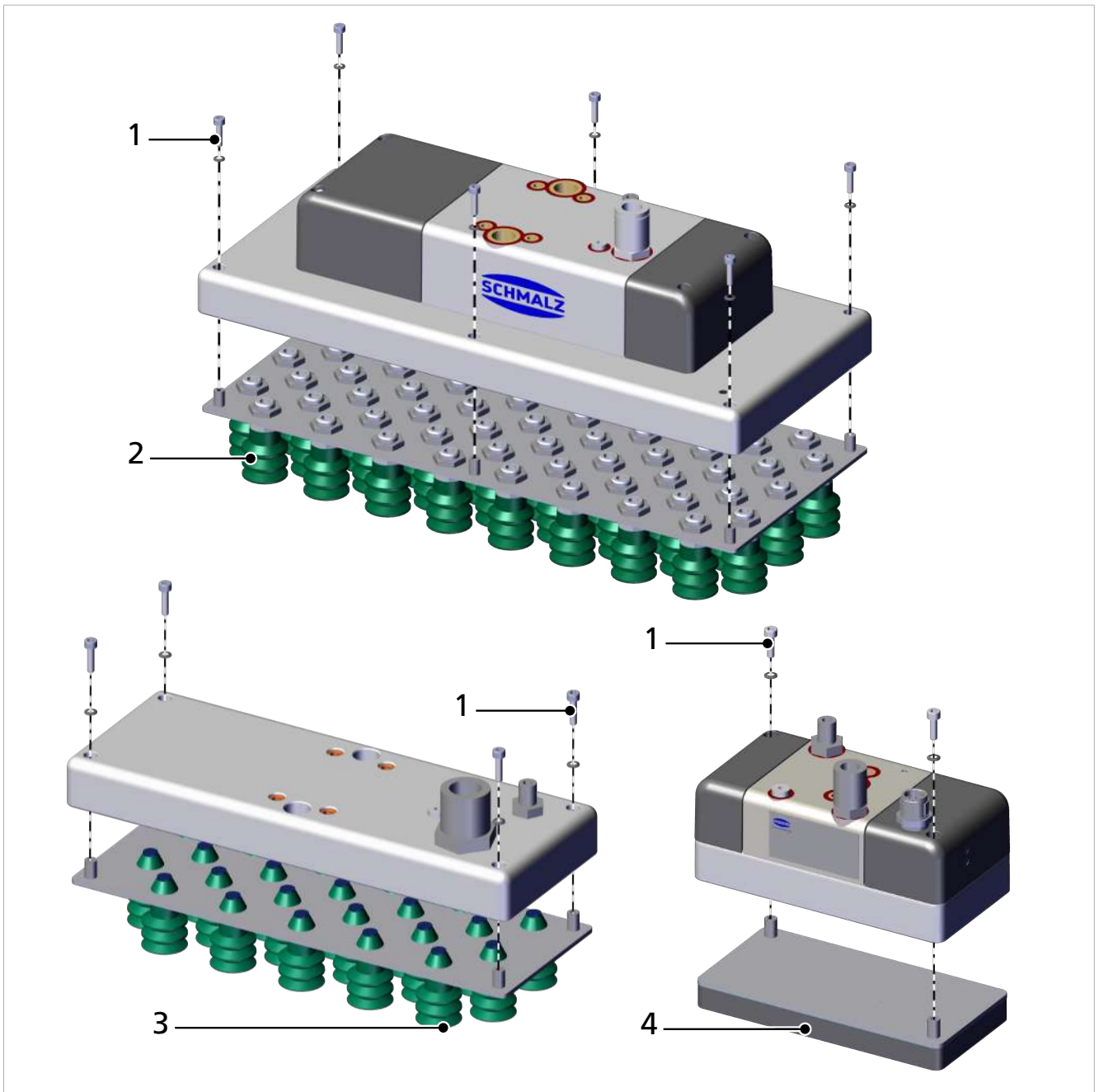

1	Screw	2	Suction plate with screw-in suction cups
3	Suction plate with plug-in suction cups	4	Sealing plate (foam)

## 10.7 Replacing the Sealing Plate (Foam)

The following steps apply to all sizes with a sealing plate

1. Remove the worn sealing plate from the mounting plate.
2. Clean the mounting plate. The surface must be free from grease and adhesive residues
3. Remove the protective film from the new foam
4. Place the new foam on the mounting plate

## 10.8 Replacing Screw-in Suction Cups

Screw-in suction cups can be replaced in two ways:

- Replace the entire screw-in suction cup (1) by unscrewing it in the mounting plate
- Replace the suction cup (2) by removing it from the suction cup connection nipple.

If necessary, the flow restrictor (3) can also be replaced in both versions.

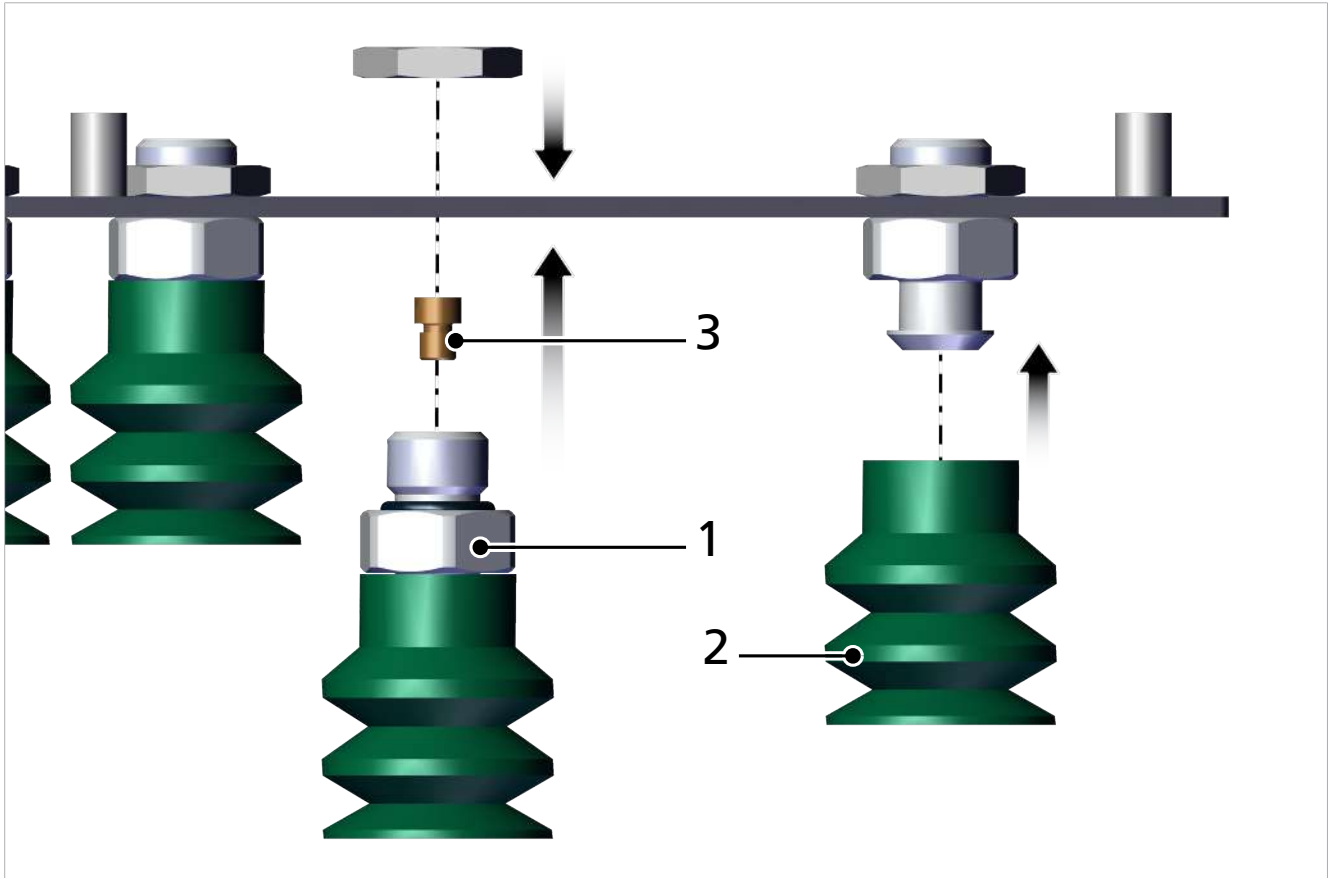

1 Screw-in suction cup  
3 Flow restrictor

2 Suction cup



## 10.9 Replacing Plug-in Suction Cups

The plug-in suction cup is destroyed while removing it

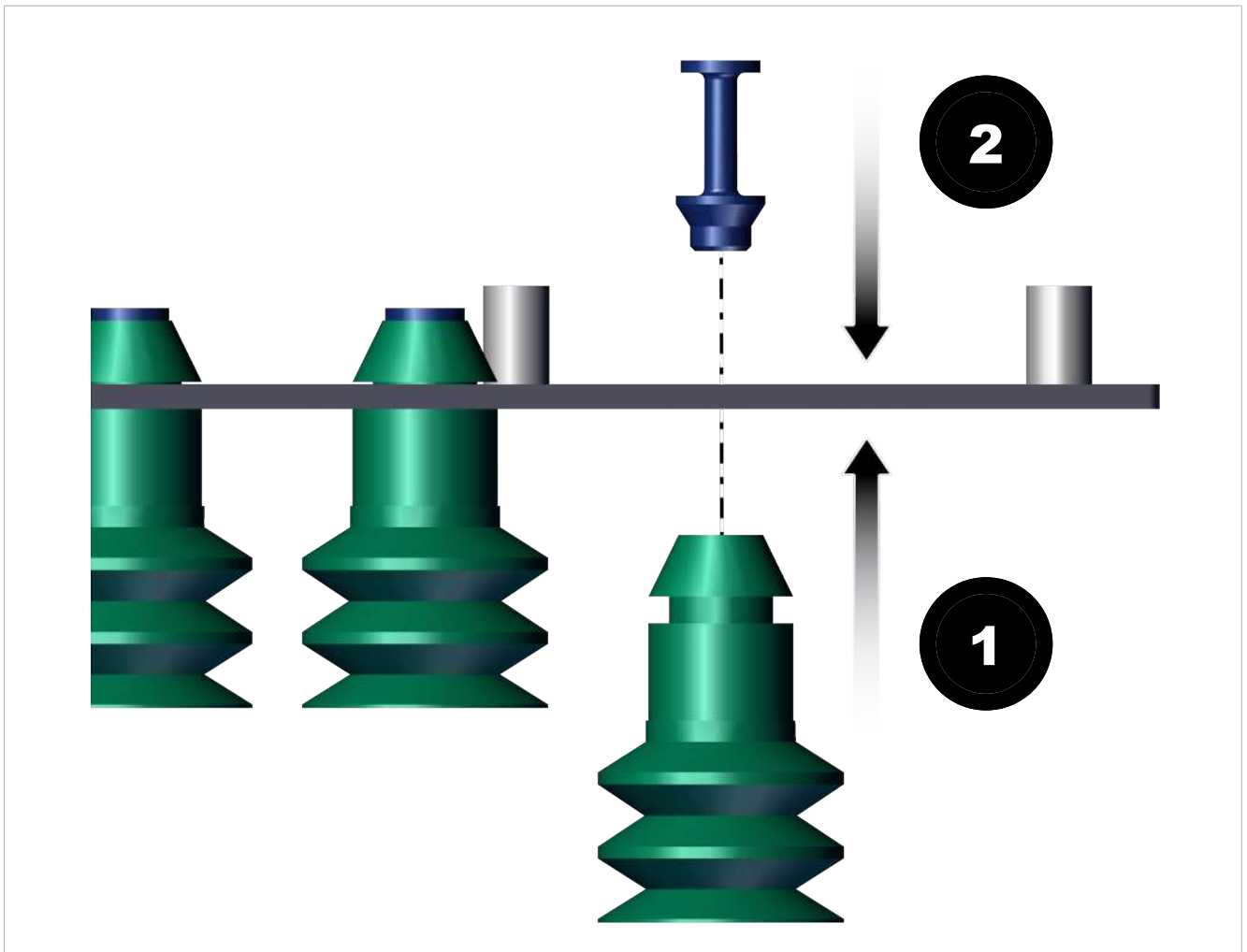

1. Plug the plug-in suction cup into the mounting plate from below
2. Plug the flow restrictor into the plug-in suction cup from above

## 10.10 Accessories, Spare Parts and Wearing Parts

Accessories, spare parts and wearing parts can be requested from the Schmalz service team using the order number, product key or product service number.

### General Accessories

Designation	Part no.	Note
Connection cable	21.04.05.00080	Straight
Connection cable	21.04.05.00557	Angled
Vacuum hose	10.07.09.00001	VSL 4-2 PU
Vacuum hose	10.07.09.00002	VSL 6-4 PU
Vacuum hose	10.07.09.00003	VSL 8-6 PU
Vacuum hose	10.07.09.00083	VSL 10-7
Vacuum hose	10.07.09.00037	VSL 12-9 PU
Vacuum hose	10.07.09.00038	VSL 14-11 PU
Vacuum hose	10.07.09.00007	VSL 26-19 PVC-DS
Vacuum gauge (manometer)	10.01.44.00249	Analog
Vacuum/pressure switch	10.06.02.00577	VSi

### Accessories for 120x60 Gripper Size

Designation	Part no.	Note
Spring plunger	10.01.02.00602	FSTE, 1/8" external thread, 15
Spring plunger	10.01.02.00605	FSTE, 1/8" external thread, 15 VG
Spring plunger	10.01.02.00603	FSTE, 1/8" external thread, 25
Spring plunger	10.01.02.00604	FSTE, 1/8" external thread, 50
Spring plunger	10.01.02.00606	FSTE, 1/8" external thread, 50 VG
Spring plunger	10.01.02.00756	FSTE-HD, 1/8" external thread, 15
Spring plunger	10.01.02.00872	FSTE-HD, 1/8" external thread, 15 VG
Spring plunger	10.01.02.00757	FSTE-HD, 1/8" external thread, 25
Spring plunger	10.01.02.00873	FSTE-HD, 1/8" external thread, 25 VG
Spring plunger	10.01.02.00758	FSTE-HD, 1/8" external thread, 50
Spring plunger	10.01.02.00874	FSTE-HD, 1/8" external thread, 50 VG
Ball joint	10.01.03.00109	KGL, 1/8", A2
Flange module	10.01.44.00195	FQE 2x connection, 120x60 incl. screws
Flange module	10.01.44.00194	FQE 3x connection, 120x60
Flange module	10.01.44.00193	FQE 4x connection, 120x60
Basic ejector	10.02.01.00565	SBP 10
Basic ejector	10.02.01.00566	SBP 15
Vacuum filter (inline)	10.07.01.00328	VFI 6/4 50
Solenoid valve	10.05.02.00162	EMVP 5 3/2 NC

## Accessories for 220x80/300x130

Designation	Part no.	Note
Spring plunger	10.01.02.00567	FSTE 1/4" external thread, 25 (2,400 N)
Spring plunger	10.01.02.00568	FSTE, 1/4" external thread, 50 (2,400 N)
Spring plunger	10.01.02.00569	FSTE, 1/4" external thread, 75 (2,400 N)
Spring plunger	10.01.02.00570	FSTE, 1/4" external thread, 25 VG (2,400 N)
Spring plunger	10.01.02.00571	FSTE, 1/4" external thread, 75 VG (2,400 N)
Spring plunger	10.01.02.00763	FSTE-HD, 1/4" external thread, 25 (2,400 N)
Spring plunger	10.01.02.00764	FSTE-HD, 1/4" external thread, 50 (2,400 N)
Spring plunger	10.01.02.00765	FSTE-HD, 1/4" external thread, 75 (2,400 N)
Spring plunger	10.01.02.00875	FSTE-HD, 1/4" external thread, 25 VG (2,400 N)
Spring plunger	10.01.02.00876	FSTE-HD, 1/4" external thread, 50 VG (2,400 N)
Spring plunger	10.01.02.00877	FSTE-HD, 1/4" external thread, 75 VG (2,400 N)
Spring plunger	10.01.02.01056	FSTE-HD, 1/4" external thread, 90 VG (1,500N)
Spring plunger	10.01.02.00574	FSTE 1/2" external thread, 25 (4,900N)
Spring plunger	10.01.02.00575	FSTE, 1/2" external thread, 75 (4,900N)
Spring plunger	10.01.02.00576	FSTE, 1/2" external thread, 90 (4,900N)
Spring plunger	10.01.02.00770	FSTE-HD, 1/2" external thread, 25 (4,900N)
Spring plunger	10.01.02.00771	FSTE-HD, 1/2" external thread, 75 (4,900N)
Spring plunger	10.01.02.00772	FSTE-HD, 1/2" external thread, 90 (4,900N)
Spring plunger	10.01.02.00881	FSTE-HD, 1/2" external thread, 25 VG (4,900N)
Spring plunger	10.01.02.00882	FSTE-HD, 1/2" external thread, 75 VG (4,900N)
Spring plunger	10.01.02.00883	FSTE-HD, 1/2" external thread, 90 VG (4,900N)
Flexolink	10.01.03.00178	FLK, 1/4" internal thread, 1/4" external thread
Flexolink	10.01.03.00175	FLK, 1/2" internal thread, 1/2" external thread
Ball joint	10.01.03.00110	KGL, 1/4" internal thread, 1/4" external thread
Ball joint	10.01.03.00111	KGL, 1/2" internal thread, 1/2" external thread
Flange module	10.01.44.00203	2x connection module, 220x80
Flange module	10.01.44.00209	3x connection module, 220x80
Flange module	10.01.44.00208	4x connection module, 220x80
Flange module	10.01.44.00202	2x connection module, 300x130
Flange module	10.01.44.00210	3x connection module, 300x130
Flange module	10.01.44.00205	4x connection module, 300x130
Flange module	10.01.44.00204	1/4" spring plunger adapter
Flange module	10.01.44.00212	1/2" spring plunger adapter
Basic ejector	10.07.01.00122	SBPL 50 HF
Basic ejector	10.07.01.00123	SBPL 75 HF
Basic ejector	10.07.01.00128	SBPL 100 HF
Vacuum cup filter	10.07.01.00122	VFT, 3/8" internal thread, 80
Vacuum cup filter	10.07.01.00128	VFT, 3/4" internal thread, 80
Vacuum cup filter	10.07.01.00123	VFT, 3/8" internal thread, 100
Solenoid valve	10.05.02.00144	EMVP 10 3/2 NO/NC
Solenoid valve	10.05.02.00146	EMVP 15 NO/NC
Solenoid valve	10.05.02.00149	EMVP 20 3/2 NO/NC

**Spare and Wearing Parts**

<b>Designation</b>	<b>Part no.</b>	<b>Description</b>	<b>Replacement / Wearing part</b>
Sealing plate (FQE)	10.01.44.00047	Sealing for suction trough, 120x60	S
Sealing plate (FQE)	10.01.44.00037	Sealing for suction trough, 220x80	S
Sealing plate (FQE)	10.01.44.00050	Sealing for suction trough, 300x130	S
Ejector module	10.02.01.01343	SEP HF 2 06 13	S
Ejector module	10.02.01.01347	SEP HF 2 13 22	S
Plug	10.01.44.00061	Instead of ejector module 2-13-22	S
Silencer insert	10.01.44.00021	for 120x60	S
Silencer insert	10.01.44.00116	for large version/ Set – consisting of 4 parts	S
Silencer cap	10.01.44.00001	small	S
Silencer cap	10.01.44.00030	large	S
Plug-in screw union, straight	10.08.02.00200	M5 AG4	S
Sealing screw with collar	10.08.06.00064	M5	S
Plug-in screw union, bracket	10.08.02.00155	M5 AG4	S
Plug-in screw union, straight	10.08.02.00204	STV-GE, 1/8" external thread, 6	S
Plug-in screw union, bracket	10.08.02.00158	STV-W, 1/8" external thread, 6	S
Plug-in screw union, straight	10.08.02.00206	1/8" external thread, 8	S
Plug-in screw union, bracket	10.08.02.00160	1/8" external thread, 8	S
Plug-in screw union, straight	10.08.02.00202	1/8" external thread, 4	S
Sealing screw with collar	10.08.06.00043	1/8"	S
Plug-in screw union, bracket	10.08.02.00156	1/8" external thread, 4	S
Plug-in screw union, straight	10.08.02.00207	STV-GE, 1/4" external thread, 8	S
Plug-in screw union, bracket	10.08.02.00161	STV-W, 1/4" external thread, 8	S
Plug-in screw union, bracket	10.08.02.00171	STV-WF, 1/4" external thread, 8	S
Plug-in screw union, straight	10.08.02.00128	STV-GE, 1/4" external thread, 10	S
Plug-in screw union, bracket	10.08.02.00254	STV-W, 1/4" external thread, 10	S
Plug-in screw union, bracket	10.08.02.00258	STV-WF, 1/4" external thread, 10	S
Plug-in screw union, straight	10.08.02.00210	STV-GE, 1/2" external thread, 12	S
Plug-in screw union, bracket	10.08.02.00164	STV-W, 1/2" external thread, 12	S
Plug-in screw union, straight	10.08.02.00300	STV-GE, 1/2" external thread, 14	S
Plug-in screw union, bracket	10.08.02.00273	STV-W, 1/2" external thread, 14	S
Hose sleeve	10.08.03.00163	ST, 1/2" external thread, 19 MS-V	S
Machine screw	20.01.02.00504	for silencer cap, 120x60	S
Machine screw	20.01.02.04002	for silencer cap, 220x80/300x130 (identical)	S
Machine screw	20.01.02.00001	M3x10 attachment, mounting plate to suction trough, 120x60	S
Machine screw	20.01.02.00002	M3x12 attachment, mounting plate to suction trough, 220x80/300x130	S
Machine screw	20.01.02.00006	M3x16 attachment, mounting plate to suction trough, FQE-M (FM), 300x130	S

Designation	Part no.	Description	Replacement / Wearing part
Safety washer	20.06.02.00027	for 120x60	S
Sealing plate	10.01.44.00007	120x60 O10	W
Sealing plate	10.01.44.00137	120x60 O20	W
Sealing plate	10.01.44.00140	120x60 O10O10F	W
Sealing plate	10.01.44.00058	220x80 O10	W
Sealing plate	10.01.44.00156	220x80 O20	W
Sealing plate	10.01.44.00176	220x80 O10O10F	W
Sealing plate	10.01.44.00052	300x130 O10	W
Sealing plate	10.01.44.00180	300x130 O20	W
Sealing plate	10.01.44.00189	300x130 O10O10F	W
Protection cover	10.01.44.00152	120.5x60.5 SU	W
Protection cover	10.01.44.00173	218x78 SU	W
Protection cover	10.01.44.00185	298x128 SU	W
Bellows suction cup	10.01.06.03125	SPB2 20 SI-40 P	W
Filter screen	10.01.06.02567	FD 18 120	W
Flow restrictor	10.05.04.00090	SW-80-P-7.3	S
Flow restrictor	10.05.04.00091	SW-100-P-7.3	S
Flow restrictor	10.05.04.00092	SW-130-P-7.3	S
Bellows suction cup	10.01.44.00131		W
Bellows suction cup	10.01.06.03409		W
Filter screen	10.01.06.02567	FD 18 120	W
Screw-in nozzle	10.05.04.00022	Flow restrictor (SW) 60	S
Screw-in nozzle	10.05.04.00024	Flow restrictor (SW) 80	S
Screw-in nozzle	10.05.04.00026	Flow restrictor (SW) 100	S
Screw-in nozzle	10.05.04.00087	Flow restrictor (SW) 130	S

## 11 Disposing of the Product

Recover the disassembled parts for recycling or reuse (provided no agreement on return or disposal has been made).

1. Dispose of the product properly after replacement or decommissioning.
2. Observe the country-specific guidelines and legal obligations for waste prevention and disposal.

## 12 Declarations of Conformity

### 12.1 EU Declaration of Incorporation

The manufacturer Schmalz confirms that the product described in these instructions fulfills the following applicable EU directives:

2006/42/EC	Machinery Directive
2011/65/EU	RoHS Directive

The product specified is solely intended for installation indoors in a complete system. Startup is prohibited until the end product has been declared to comply with the Directive 2006/42/EC.

The manufacturer commits to provide special documentation of the partly completed machinery to national authorities in electronic form if requested. The special technical documentation belong to the machine as per Annex VII Part B has been created.

The following harmonized standards were applied:

EN ISO 12100	Safety of machinery — General principles for design — Risk assessment and risk reduction
EN ISO 13849-1	Safety of machinery - Safety-related parts of control systems - Part 1 General principles for design
EN 1012-1	Compressors and Vacuum Pumps - Safety requirements - Part 1: compressors
EN 50581	Technical documentation for the assessment of electrical and electronic products with respect to the restriction of hazardous substances
DIN ISO/TS 15066	Robots and robotic devices – Collaborative robots
EN ISO 10218-1	Industrial Robots – Safety Requirements – Part 1: Robots
EN ISO 10218-2	Industrial Robots – Safety Requirements – Part 2: Robot Systems and Integration



The EU Declaration of Conformity valid at the time of product delivery is delivered with product or made available online. The standards and directives cited here reflect the status at the time of publication of the operating and assembly instructions.

## 12.2 UKCA Declaration of Incorporation

The manufacturer Schmalz confirms that the product described in these operating instructions fulfills the following applicable UK regulations:

2008	Supply of Machinery (Safety) Regulations
2012	The Restriction of the Use of Certain Hazardous Substances in Electrical and Electronic Equipment Regulations

The product specified is solely intended for installation indoors in a complete system. The start of operations shall be prohibited until the conformity of the final product with the "Supply of Machinery (Safety) Regulations 2008" has been established.

The manufacturer commits to provide special documentation of the partly completed machinery to national authorities in electronic form if requested. The special technical documentation belonging to the machine as per Annex VII Part B has been created.

The following designated standards were applied:

EN ISO 12100	Safety of machinery — General principles for design — Risk assessment and risk reduction
EN ISO 13849-1	Safety of machinery - Safety-related parts of control systems - Part 1 General principles for design
EN 1012-1	Compressors and Vacuum Pumps - Safety requirements - Part 1: compressors
EN 50581	Technical documentation for the assessment of electrical and electronic products with respect to the restriction of hazardous substances
DIN ISO/TS 15066	Robots and robotic devices – Collaborative robots
EN ISO 10218-1	Industrial Robots – Safety Requirements – Part 1: Robots
EN ISO 10218-2	Industrial Robots – Safety Requirements – Part 2: Robot Systems and Integration



The Declaration of Conformity (UKCA) valid at the time of product delivery is delivered with the product or made available online. The standards and directives cited here reflect the status at the time of publication of the operating and assembly instructions.





---

## At Your Service Worldwide



---

### Vacuum Automation

[WWW.SCHMALZ.COM/AUTOMATION](http://WWW.SCHMALZ.COM/AUTOMATION)

### Handling Systems

[WWW.SCHMALZ.COM/AUTOMATION](http://WWW.SCHMALZ.COM/AUTOMATION)

---

**J. Schmalz GmbH**  
Johannes-Schmalz-Str. 1  
72293 Glatten, Germany  
T: +49 (0) 7443 2403-0  
schmalz@schmalz.de  
WWW.SCHMALZ.COM